

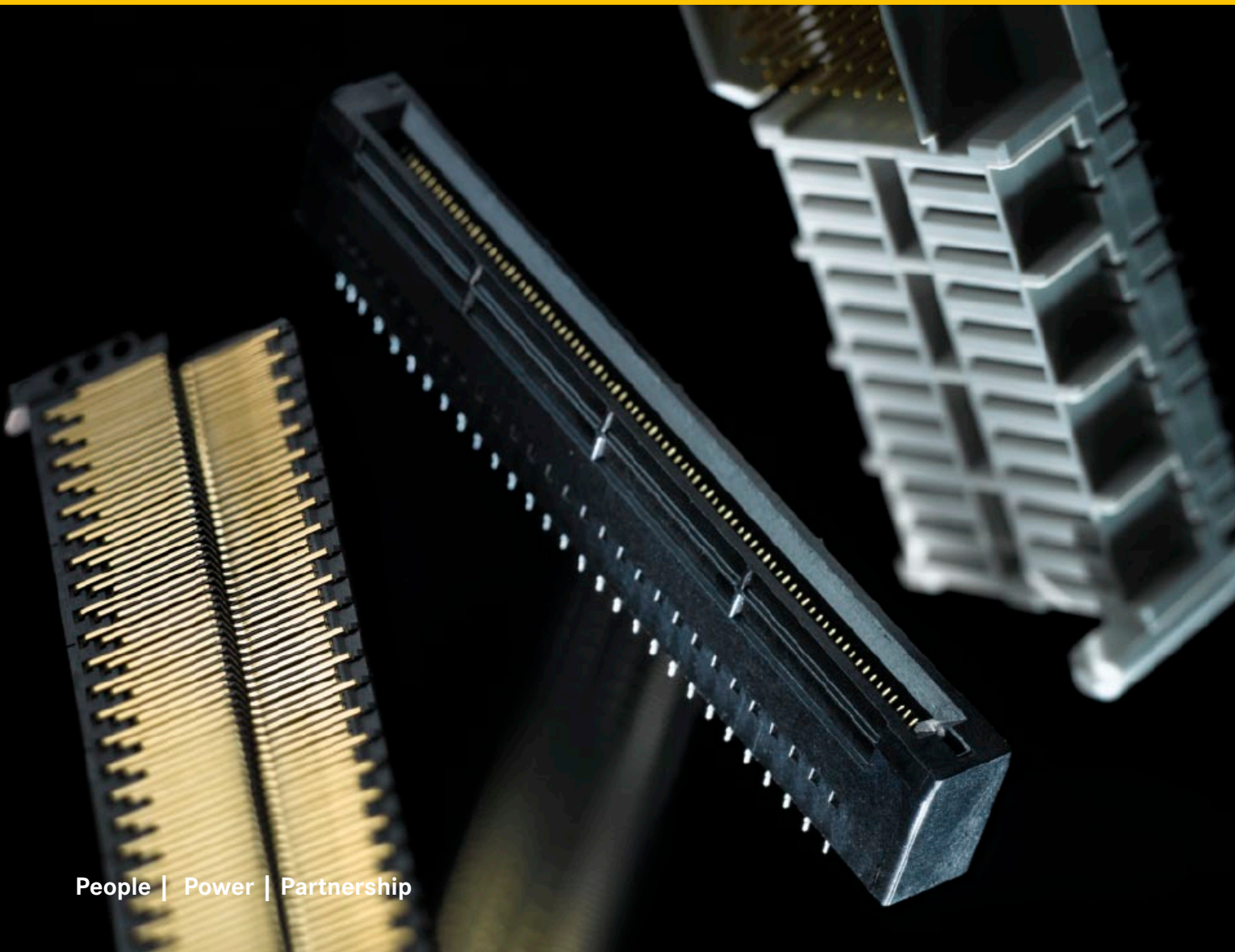

Pushing Performance

HARTING TCA Connectors



Transforming customer wishes into concrete solutions



The HARTING Technology Group is skilled in the fields of electrical, electronic and optical connection, transmission and networking, as well as in manufacturing, mechatronics and software creation. The Group uses these skills to develop customized solutions and products such as connectors for energy and data transmission applications including, for example, mechanical engineering, rail technology, wind energy plants, factory automation and the telecommunications sector. In addition, HARTING also produces electro-magnetic components for the automobile industry and offers solutions in the field of Enclosures and Shop Systems.

The HARTING Group currently comprises 32 subsidiary companies and worldwide distributors employing a total of approximately 3,200 staff.



HARTING Subsidiary company



HARTING Representatives



We aspire to top performance.

Connectors ensure functionality. As core elements of electrical and optical wiring, connection and infrastructure technologies, they are essential in enabling the modular construction of devices, machines and systems across a very wide range of industrial applications. Their reliability is a crucial factor guaranteeing smooth functioning in the manufacturing area, in telecommunications, applications in medical technology – in fact, connectors are at work in virtually every conceivable application area. Thanks to the consistent further development of our technologies, customers enjoy investment security and benefit from durable, long term functionality.

Always at hand, wherever our customers may be.

Increasing industrialization is creating growing markets characterized by widely diverging demands and requirements. The search for perfection, increasingly efficient processes and reliable technologies is a common factor in all sectors across the globe.

HARTING is providing these technologies – in Europe, America and Asia. The **HARTING** professionals at our international subsidiaries engage in close, partnership based interaction with our customers, right from the very early product development phases, in order to realize customer demands and requirements in the best possible manner.

Our people on location form the interface to the centrally coordinated development and production departments. In this way, our customers can rely on consistently high, superior product quality – worldwide.

Our claim: pushing performance.

HARTING provides more than optimally attuned components. In order to serve our customers with the best possible solutions, **HARTING** is able to contribute a great deal more and play a closely integrative role in the value creation process.

From ready assembled cables through to control racks or ready-to-go control desks: Our aim is to generate the maximum benefits for our customers – without compromise!

Quality creates reliability – and warrants trust.

The **HARTING** brand stands for superior quality and reliability – worldwide. The standards we set are the result of consistent, stringent quality management that is subject to regular certifications and audits.

EN ISO 9001, the EU Eco-Audit and ISO 14001:2004 are key elements here. We take a proactive stance to new requirements, which is why **HARTING** ranks among the first companies worldwide to have obtained the new IRIS quality certificate for rail vehicles.



HARTING technology creates added value for customers.

Technologies by **HARTING** are at work worldwide. **HARTING's** presence stands for smoothly functioning systems, powered by intelligent connectors, smart infrastructure solutions and mature network systems. In the course of many years of close, trust-based cooperation with its customers, the **HARTING** Technology Group has advanced to one of the worldwide leading specialists for connector technology. Extending beyond the basic functionalities demanded, we offer individual customers specific and innovative solutions. These tailored solutions deliver sustained effects, provide investment security and enable customers to achieve strong added value.

Opting for HARTING opens up an innovative, complex world of concepts and ideas.

In order to develop connectivity and network solutions serving an exceptionally wide range of connector applications and task scopes in a professional and cost optimized manner, **HARTING** not only commands the full array of conventional tools and basic technologies. Over and beyond these capabilities, **HARTING** is constantly harnessing and refining its broad base of knowledge and experience to create new solutions that ensure continuity at the same time. In securing this know-how lead, **HARTING** draws on a wealth of sources from both in-house research and the world of applications alike.

Salient examples of these sources of innovative knowledge include microstructure technologies, 3D design and construction technology, as well as high temperature

or ultrahigh frequency applications that are finding use in telecommunications or automation networks, in the automotive industry, or in industrial sensor and actuator applications, RFID and wireless technologies, in addition to packaging and housing made of plastics, aluminum or stainless steel.

HARTING solutions extend across technology boundaries.

Drawing on the comprehensive resources of the group's technology pool, **HARTING** devises practical solutions for its customers. Whether this involves industrial networks for manufacturing automation, or hybrid interface solutions for wireless telecommunication infrastructures, 3D circuit carriers with microstructures, or cable assemblies for high-temperature applications in the automotive industry – **HARTING** technologies offer far more than components, and represent mature, comprehensive solutions attuned to individual customer requirements and wishes. The range covers ready-to-use cable configurations, completely assembled backplanes and board system carriers, as well as fully wired and tested control panels.

In order to ensure the future proof design of RF- and EMC-compatible interface solutions, the central **HARTING** laboratory (certified to EN 45001) provides simulation tools, as well as experimental, testing and diagnostics facilities all the way through to scanning electron microscopes. In the selection of materials and processes, lifecycle and environmental aspects play a key role, in addition to product and process capability considerations.



HARTING knowledge is practical know-how generating synergy effects.

HARTING commands decades of experience with regard to the applications conditions of connectors in telecommunications, computer and network technologies and medical technologies, as well as industrial automation technologies, such as the mechanical engineering and plant engineering areas, in addition to the power generation industry or the transportation sector. **HARTING** is highly conversant with the specific application areas in all of these technology fields.

The key focus is on applications in every solution approach. In this context, uncompromising, superior quality is our hallmark. Every new solution found will invariably flow back into the **HARTING** technology pool, thereby enriching our resources. And every new solution we go on to create will draw on this wealth of resources in order to optimize each and every individual solution. In this way, **HARTING** is synergy in action.

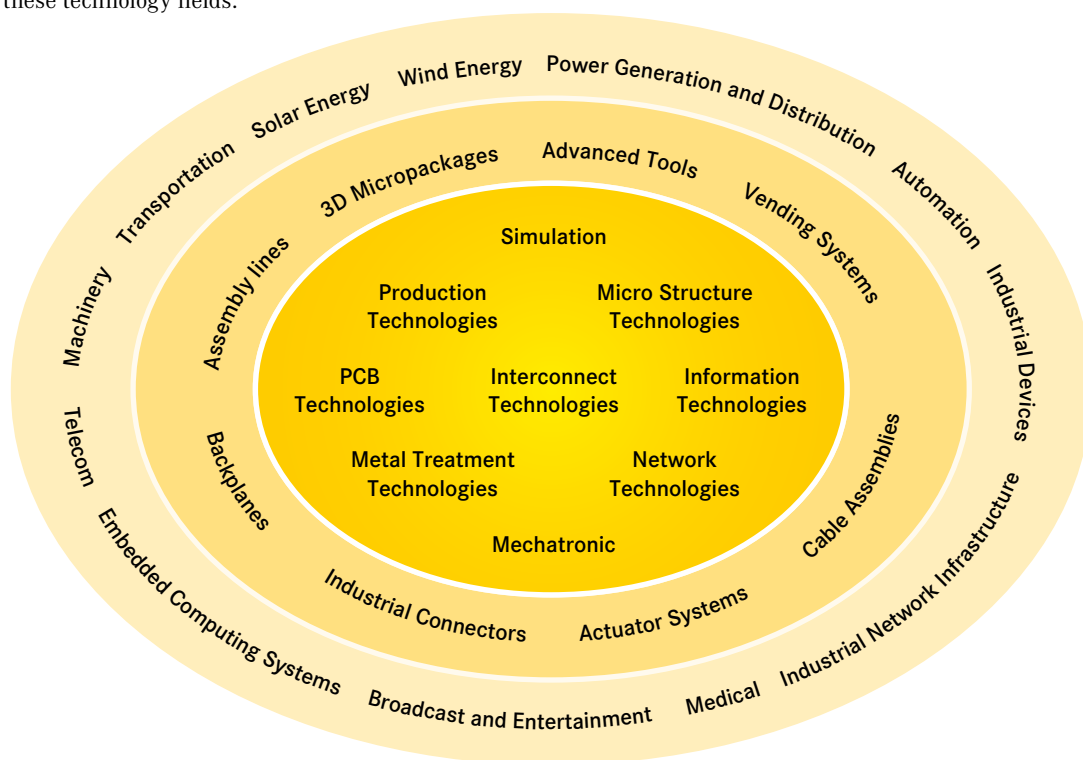



HARKIS® is the abbreviation for **HARTING-Katalog-Informationen-System** (HARTING catalogue information system).

HARKIS® is an electronic catalogue with part configuration and 3D components library. Here you can choose a connector according to your demands. Afterwards you are able to send your inquiry created with the listed parts. The drawings to every single part are available in PDF-format. The parts are downloadable in 2D-format (DXF) and 3D-format (IGES, STEP). The 3D-models can be viewed with a VRML-viewer.

You can find **HARKIS®** at www.HARKIS.HARTING.com. It is also available on CD-ROM and DVD.



Piece part consulting



CAD library

Product samples: Fast-track delivery to your desk, free of charge

With immediate effect, the new express sample dispatching service in the HARTING catalogue information system (**HARKIS®**) allows customers to order samples immediately, easily and free of charge on express delivery. A broad selection from the device connectivity product portfolio is now available. In the case of unavailable items the system offers alternative products with similar features that can be requested at a mouse click.

The samples are shipped within 48 hours after your order, free of charge. This service enables tremendous flexibility, especially in the design phase of projects.

Identification

Part number

HARKIS® CD-ROM
Basic product catalogue

98 40 000 0401

HARKIS® DVD
Basic product catalogue
2D and 3D CAD files inclusive

98 40 000 0405



General information

It is the customer's responsibility to check whether the components illustrated in this catalogue comply with different regulations from those stated in special fields of application which we are unable to foresee.

We reserve the right to modify designs in order to improve quality, keep pace with technological advancement or meet particular requirements in production.

No part of this catalogue may be reproduced in any form (print, photocopy, microfilm or any other process) or processed, duplicated or distributed by means of electronic systems without the written permission of HARTING Electronics GmbH & Co. KG, Espelkamp. We are bound by the English version only.

TCA connectors

Page

General information 8



..... 10

AdvancedMC™ connectors
for AdvancedTCA® 12



Power connectors
for AdvancedTCA® 14



AdvancedMC™ connectors
for MicroTCA™ 16

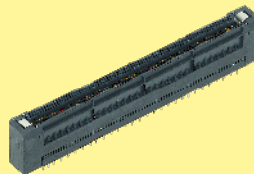

Power output connectors
for MicroTCA™ 18

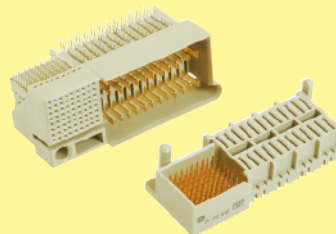

Plug Connectors for
AdvancedMC™ modules 21

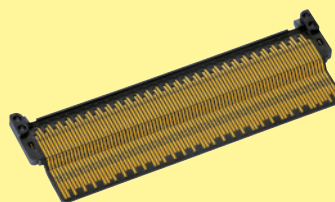

Press-in tooling 30

Signal integrity support 32

List of part numbers 34

Company addresses 36



PICMG, formally known as the PCI Industrial Computing Manufacturing Group – is an industry consortium of over 450 companies. PICMG’s purpose is to define standard architectures in an effort to reduce system costs and development

cycles and since its 1994 foundation, PICMG has been responsible for the establishment of several of successfully implemented, open, industrial standards. Open standards have proven themselves to be very advantageous for system manufacturers and end-user, because they create multiple vendors of similar parts, low prices at high volumes, and a shortened time-to-market.

Historically, PICMG has created several successful standards.

- PICMG 1.x Series – a passive backplane PCI specification
- PICMG 2.x Series – the CompactPCI® standard

AdvancedTCA®

Today, the AdvancedTCA® series of specifications (PICMG 3.x) targets the requirements of the next generation of carrier grade telecommunications equipment. AdvancedTCA®, short for Advanced Telecom Computing Architecture and sometimes simply abbreviated ATCA®, incorporates an impressive suite of recent technological advancements including the latest trends in high speed interconnect technologies.

Features of AdvancedTCA® include optimization for high-capacity, high-performance telecom and industrial applications, improved reliability, manageability, redundancy, and serviceability. Encompassing a technological growth path valid for up to ten years, AdvancedTCA® has earned a solid position within the telecom systems market.

The rack or chassis, is responsible for housing the backplane and the daughtercards, as well as cooling



AdvancedTCA® chassis with backplane

and powering the system. HARTING offers the ATCA® power connector that energises the blades, both the straight backplane and the right angled daughtercard connector.

The backplane, said to be passive, is merely a medium for the daughtercards to communicate with each other. And, the daughtercards, sometimes called blades or boards, provide the system with its functionality and allow for an easy, hot-swappable module exchange from the front of the system.

Initially, many blades were designed with a fixed functionality, and they had to be replaced once their functionality became obsolete or the demands of the system changed. With the continuation of exponential technological growth, concept proved to be a costly endeavour for the end-user.

AdvancedMC™

To extend the functionality and modularity of AdvancedTCA®, blade manufacturers conceived the idea of upgradeable daughtercards, and began to insert mezzanine cards onto the blades when needed. To achieve a common mezzanine concept, PICMG developed the Advanced Mezzanine Card (AdvancedMC™) standard AMC.0.

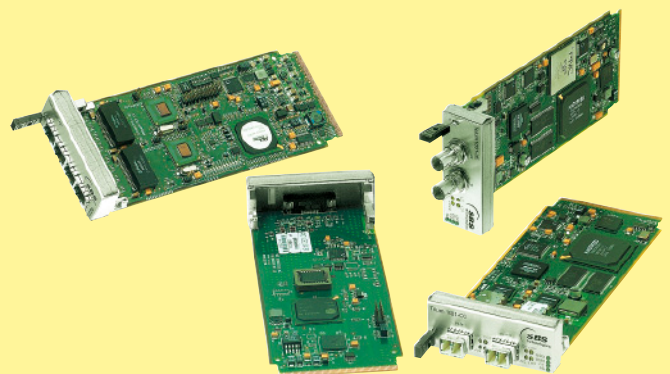

AdvancedMC™ modules for different applications

For the use of Advanced Mezzanine Cards, as well called AdvancedMC™ modules, a carrier is necessary. A carrier is an ATCA® blade with only little functionality beyond AdvancedMC™ management. It contains the mechanical environment for the AdvancedMC™ modules. Depending on their size, up to eight AdvancedMC™ modules can be hot-swapped in and out of a carrier, this enabled the creation of extremely scalable and upgradeable systems.

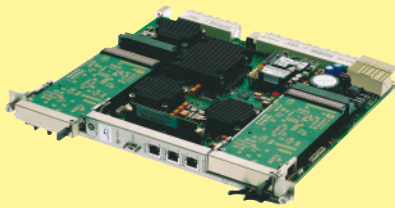

AdvancedTCA[®] carrier board with AdvancedMC[™] modules

To connect AdvancedMC[™] modules to carrier boards PICMG defined a new high-speed mezzanine connector: the AdvancedMC[™] connector – a card edge connector mounted on the carrier board. It contacts directly with the module's PCB gold pads. Although PICMG defined four AdvancedMC[™] connector types (B, B+, AB and A+B+), current market developments focus on type B+.

The HARTING AdvancedMC[™] B+ connector features a new design element that supplements the standard – the GuideSpring. The GuideSpring significantly increases the mating reliability and prevents contact interruptions and surface wear when subjected to shocks or vibrations.

The press-fit termination technology provides significant cost and durability advantages over other termination technologies. The connector design allows for the use of a standard flat rock die. For more press-in process control, HARTING offers a special top and bottom tool (see page 30).

The HARTING AdvancedMC[™] Plug Connector can replace the module's PCB gold pads and increase the contact reliability from the module side. Please find more information about the HARTING AdvancedMC[™] Plug Connector on page 21ff.

μTCA[™]

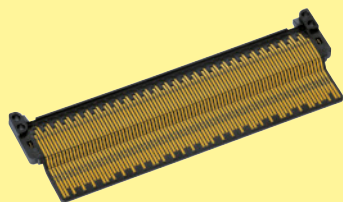

This revolutionary AdvancedMC[™]-based design concept has led to the recent development of a completely mezzanine-based system – MicroTCA[™]. MicroTCA[™], short for Micro Telecom Computing Architecture, is a more cost-efficient platform than AdvancedTCA[®] when dealing with smaller applications, yet powerful enough to address the needs of telecom, enterprise and medical applications.

This newly-implemented PICMG standard, outlined in the MTCA.0 specification, presents a design-concept whereby AdvancedMC[™]s – the same kind used in ATCA[®] systems – plug directly into a passive backplane; this eliminates the need for carrier boards.



MicroTCA[™] double cube system

Naturally the mating face of the AdvancedMC[™] connector for MicroTCA[™] is the same as for ATCA[®], but with a right angled mating direction. It contains the new GuideSpring and is available in press-in termination. PICMG members voted HARTING's MicroTCA[™] connector footprint as the new MicroTCA[™] standard connector for press-fit termination technology.

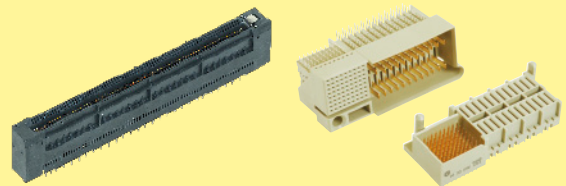

AdvancedMC[™] and power connectors for MicroTCA[™]

The MicroTCA[™] backplane is typically powered by special, field replaceable, hot-swappable, redundant Power Supply Units (PSU). The PSU connects to the backplane through a MicroTCA[™] power connector (press-fit termination) also available from HARTING.

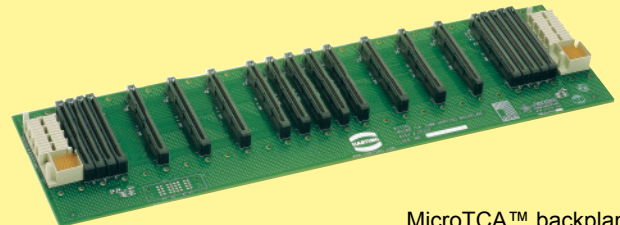

MicroTCA[™] backplane

The module management is performed by a MicroTCA[™] Carrier Hub, or MCH. An MCH is connected to the backplane by up to four adjacent card-edge connectors. One MCH can control up to 12 AdvancedMC[™] modules, thus depending on redundancy requirements, workload, or both, one or two MCHs may be used within a single system.

For a precise mechanical alignment of the mating tongues HARTING offers the special Plug Connectors according to MTCA.0.

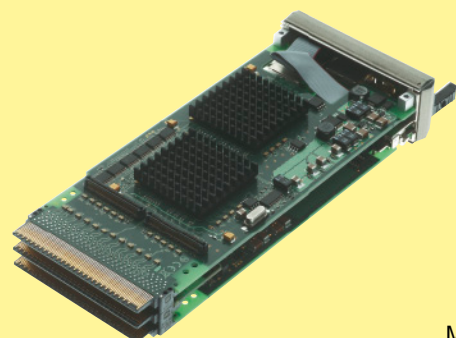

MCH board

What is con:card+?

con:card+ is a quality seal for AdvancedMC™ connectors that helps to deliver a significant increase in the reliability of MicroTCA™ and AdvancedTCA® systems. In order to reach the target availability of 99.999 %, all system components must be carefully coordinated, and they must function reliably. The selection of suitable connectors is an essential, decisive factor here, as today it is virtually impossible for series production to meet the strict tolerances for the AdvancedMC™ modules as defined in the respective specifications. The so-called GuideSpring is ideally suited for compensating here, and represents just one of a total of five key advantages of the **con:card+** philosophy. All the advantages are introduced in the following. Please find further information also on the internet at www.concardplus.com.



Special contact design

Unlike conventional mating systems with male and female connectors, the AdvancedMC™ has only one, not two, contact tongues per contact. In order to ensure a permanently reliable contact, this single contact tongue must press against the gold pad with sufficient force throughout the entire lifetime. In addition, the thickness of the AdvancedMC™ modules may fluctuate by $\pm 10\%$. To meet this challenge, HARTING utilizes a special contact design with very low relaxation for the **con:card+** connector.



PdNi contact coating

In order better to meet the high requirements placed on the connectors, a palladium-nickel surface (PdNi) with additional gold flash is used. As a result, wear resistance is increased by roughly 30 %. Even when applied very thinly, PdNi surfaces offer a quality and corrosion-resistant coating that meets the high requirements placed on the connection far better than pure gold.





Smooth contact surface

The specification for the AdvancedMC™ entails 200 mating cycles for a module. On the PCB, the nickel/hard gold layer on the relatively soft copper can only stand up to this high load if the contact surface is absolutely smooth.

This is the case with the **con:card+** connector. With years of experience in stamping techniques and the utilization of high-performance stamping tools with special process components, HARTING is actively involved in minimizing gold pad wear.

GuideSpring

PCB manufacturers are not capable of meeting the AdvancedMC™ modules' tight tolerances with certainty in the series process today. Just a single card with tolerances slightly larger than allowed by the specifications can lead to a system breakdown.

The **con:card+** GuideSpring offsets these tolerance deviations by constantly pressing the module against the opposite wall. As this is displaced somewhat towards the middle, the slot is optimally designed for the AdvancedMC™ module, and the mating reliability increases tremendously.

In addition, the GuideSpring secures the module position in the case of shocks and vibrations. This prevents loss of contact and surface wear.

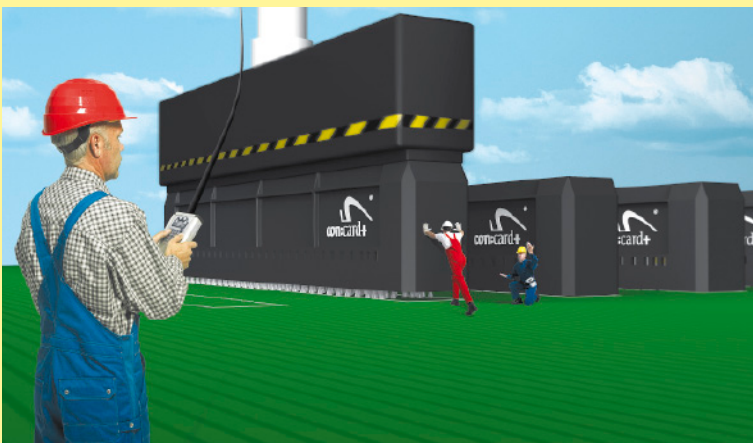
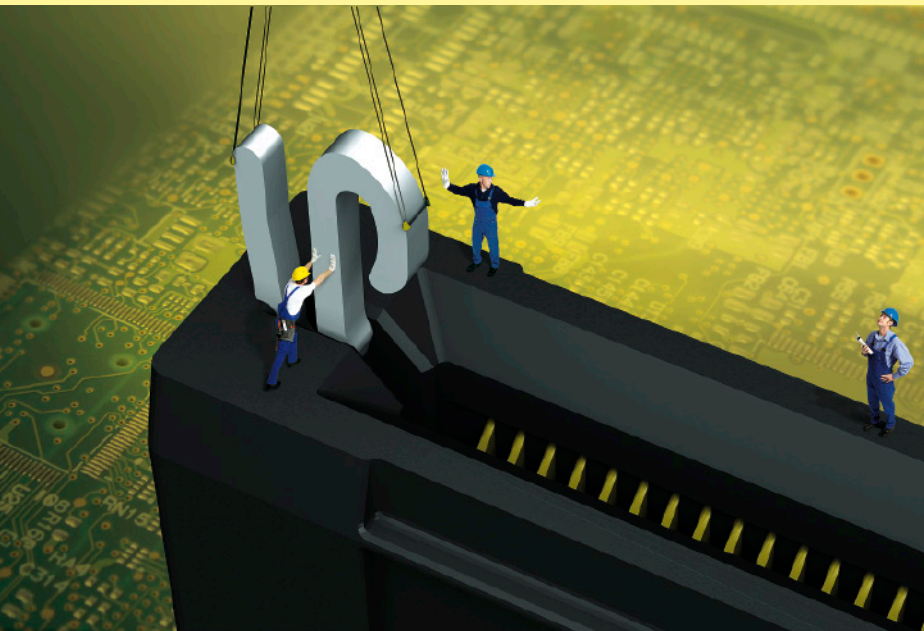

Press-fit technology

Press-fit technology results in a gas-tight, corrosion-resistant, low-ohm quality mechanical connection between the pin and the through contacting of the PCB. This remains reliably in contact and stable, even under conditions of high mechanical and thermal loads, such as vibration, bending and frequent temperature changes. This technology represents a tremendous advantage over other processing techniques. Measurements substantiate that the required transmission rates are easily attained.

Technical characteristics

Design according	PICMG AMC.0 (RoHS compliance)
Number of contacts	170
Contact spacing	0.75 mm
Clearance and creepage distance between contacts	0.1 mm min.
Working current of power contacts as defined in AMC.0 spec.	~ 2.9 A @ 70 °C max. 30 °C temp. rise (PICMG requirement min. 1.52 A)
Test voltage	80 V _{r.m.s.}
Working voltage typically	3.3 V; 5.0 V; 12.0 V
Initial contact resistance ground contacts	60 mΩ max.
signal, power, general purpose contacts	90 mΩ max.
Initial insulation resistance	100 MΩ min.

Nominal differential impedance 100 Ω±10 %

Max. crosstalk @ 25 ps risetime	Bottom route
Adjacent	0.55 %
Basic-to-extended (diagonal)	0.68 %
Basic-to-extended (opposite)	0.39 %
Multiline (five multi-aggressor differential pairs)	2.74 % max.

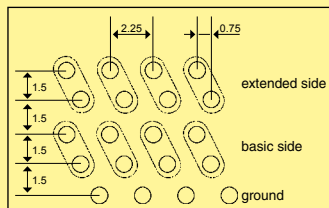

PCB library on request (PADS/Dx-Designer)
SPICE models and S-Parameter on request

Differential propagation delay	Basic side: 125 ps Extended side: 145 ps
Differential skew	Between basic and extended side: 20 ps Within basic and extended side: ±2 ps

Temperature range	-55 °C ... +105 °C
Durability as per AMC.0 specification	200 mating cycles
Termination technique	Press-in termination
Mating force	100 N max., typically 65 - 90 N (depending on AdvancedMC™)
Withdrawal force	65 N max., typically 30 - 45 N (depending on AdvancedMC™)

Materials

Moulded parts	Liquid Crystal Polymer (LCP), UL 94-V0
Contacts	Copper Alloy
Contact surface	Pd/Ni with Au flash

Packaging Cardboard box (other packaging on request)

Recommended plated through hole specification

	A	Drill hole-Ø	0.64±0.01 mm
	B	Cu	25 - 35 µm
Tin plated PCB (HAL)	C	Sn	5 - 15 µm
	D	Hole-Ø	0.53 - 0.60 mm
Au / Ni plated PCB	C	Ni	3 - 7 µm
		Au	0.05 - 0.12 µm
	D	Hole-Ø	0.55 - 0.60 mm
Chemical tin plated PCB	C	Sn	0.8 - 1.5 µm
	D	Hole-Ø	0.56 - 0.60 mm
Silver plated PCB	C	Ag	0.1 - 0.3 µm
	D	Hole-Ø	0.56 - 0.60 mm
OSP copper plated PCB	C	---	---
	D	Hole-Ø	0.56 - 0.60 mm
	E	Pad size	min. 0.95 mm

The press-in zone of the AdvancedMC™ connector is tested according to Telcordia/Bellcore GR 1217CORE Part7. It is approved to be used with a plated through hole according IEC 60352-5 with a diameter of 0.55±0.05 mm (drilled hole 0.64±0.01 mm).

Based on our experiences regarding the production process of the PCB manufacturer we recommend a plated through hole configuration like shown in the above spreadsheet. To achieve the recommended plated through hole diameter, it is important to specify especially the drilled hole diameter of 0.64±0.01 mm to your PCB supplier.

For drillings use e.g. drill bit # 72 (0.025" ≈ 0.64 mm).

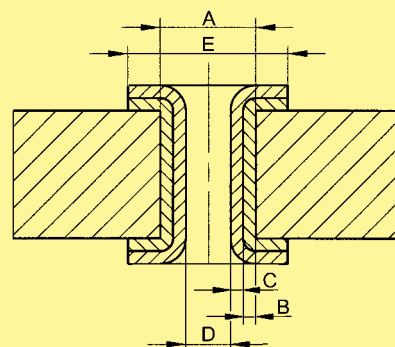

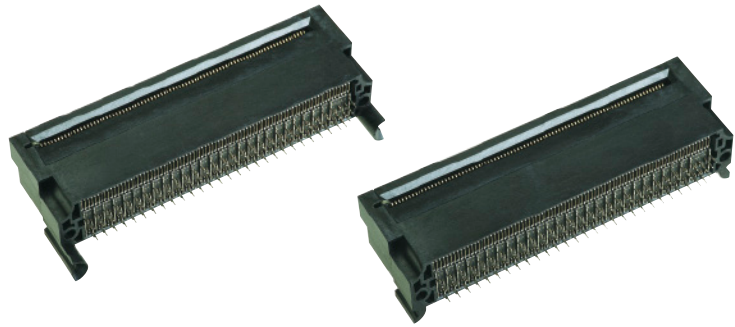

Card edge connectors, angled

Identification	No. of contacts	Contact length [mm] termination side	Part number
AdvancedMC™ connector for ATCA®, type B+ with peg and with GuideSpring	170	2.0	16 04 170 5104 000
AdvancedMC™ connector for ATCA®, type B+ without peg and with GuideSpring	170	2.0	16 04 170 5106 000

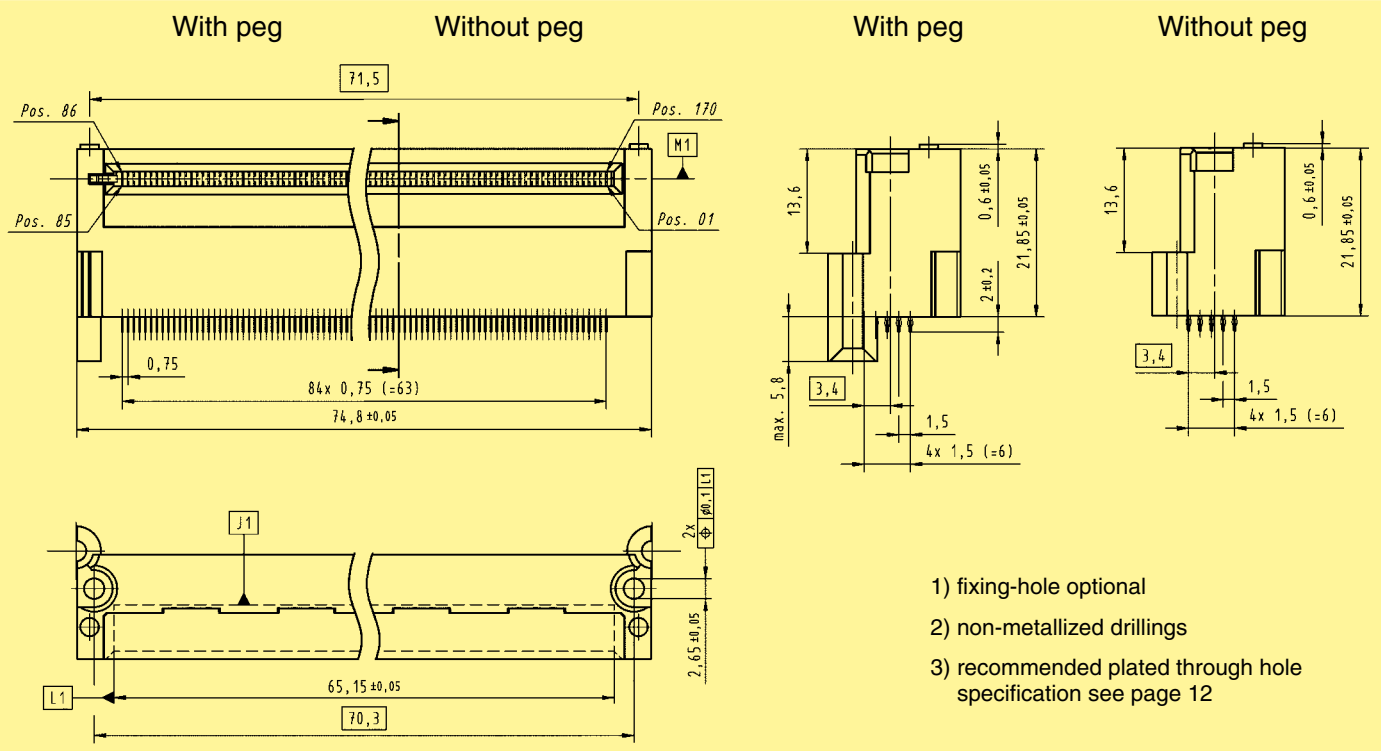

Board drillings (view magnified)

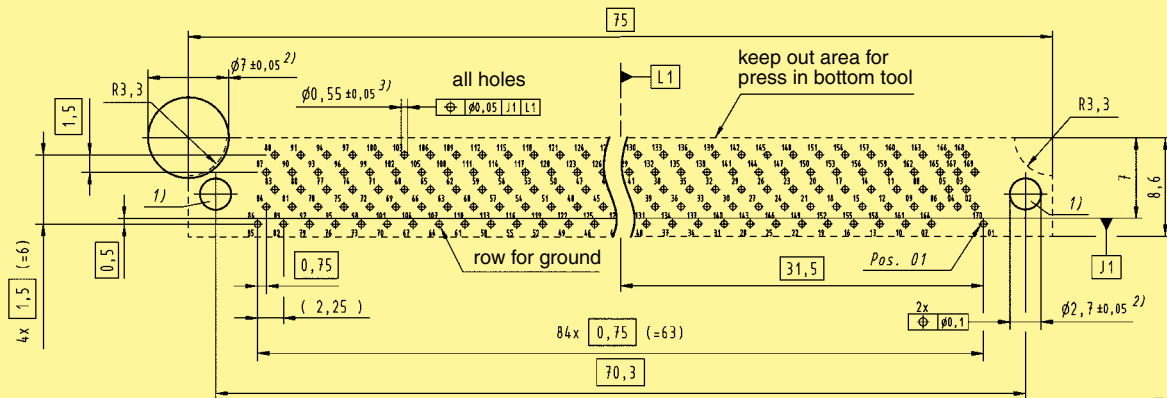

Dimensions [mm]

Technical characteristics

Design according to PICMG 3.0 R2.0

Total number of contacts: 30, max. 34
 Power contacts: 8
 Signal contacts: 22, max. 26

Clearance and creepage distance between contacts

Within group 5–16: 0.7 mm min.
 Within group 17–24: 2.5 mm min.
 25 to 26: 5.5 mm min.
 Within group 27–34: 1.4 mm min.
 13–16 to 17–20: 3.0 mm min.
 21–24 to 25–26: 4.0 mm min.
 25–26 to 27–29: 2.0 mm min.

Sequential contact engagement

1st: 25, 26, 28, 29, 30, 31
 2nd: 33
 3rd: 5–24, 34
 4th: 27, 32

Working current

Power contacts: 16 A
 Signal contacts: 1 A

Test voltage

Contacts 1–16: 1000 V_{r.m.s.}
 Contacts 17–34: 2000 V_{r.m.s.}

Initial contact resistance

Power contacts: ≤ 2.2 mΩ
 Signal contacts: ≤ 8.5 mΩ

Insulation resistance

≥ 10¹⁰ Ω

Temperature range

-55 °C ... +125 °C

Durability

250 mating cycles

Termination technique

Press-in termination

Mating force

67 N max.

Withdrawal force

67 N max.

Derating for ATCA® power contacts

Contact loading acc. PICMG 3.0

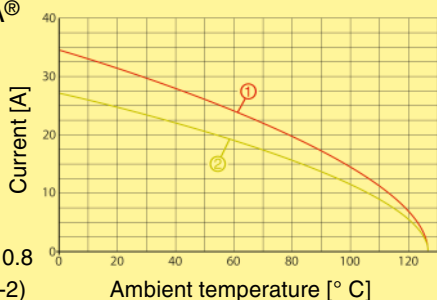

① Derating

② Derating @ I_{max} x 0.8 (acc. IEC 60512-5-2)

Materials

Moulded parts: PBT, glass-fibre filled, UL 94-V0

Contacts: Copper Alloy

Contact surface: Selectively gold plated

Packaging

Tray packaging (other packaging on request)

Recommended plated through hole specification

			Signal contacts	Power contacts
	A	Drill hole-Ø	1.15±0.025 mm	1.75±0.025 mm
	B	Cu	25 - 35 µm	25 - 35 µm
Tin plated PCB (HAL)	C	Sn	5 - 15 µm	5 - 15 µm
	D	Hole-Ø	1.00 - 1.10 mm	1.60 - 1.70 mm
Au / Ni plated PCB	C	Ni	3 - 7 µm	3 - 7 µm
		Au	0.05 - 0.12 µm	0.05 - 0.12 µm
	D	Hole-Ø	1.00 - 1.10 mm	1.60 - 1.70 mm
Chemical tin plated PCB	C	Sn	0.8 - 1.5 µm	0.8 - 1.5 µm
	D	Hole-Ø	1.00 - 1.10 mm	1.60 - 1.70 mm
Silver plated PCB	C	Ag	0.1 - 0.3 µm	0.1 - 0.3 µm
	D	Hole-Ø	1.00 - 1.10 mm	1.60 - 1.70 mm
OSP copper plated PCB	C	---	---	---
	D	Hole-Ø	1.00 - 1.10 mm	1.60 - 1.70 mm
	E	Pad size	min. 1.4 mm	min. 2.0 mm

The press-in zone of the AdvancedTCA® power connector is tested according to Telcordia/Belcore GR 1217CORE Part7. It is approved to be used with a plated through hole according IEC 60352-5 with a diameter of 1.00^{+0.09}_{-0.06} mm for signal contacts and 1.60^{+0.09}_{-0.06} mm for power contacts (drilled hole 1.15±0.025 mm resp. 1.75±0.025 mm).

Based on our experiences regarding the production process of the PCB manufacturer we recommend a plated through hole configuration like shown in the above spreadsheet. To achieve the recommended plated through hole diameter, it is important to specify especially the drilled hole diameter of 1.15±0.025 mm resp. 1.75±0.025 mm to your PCB supplier.

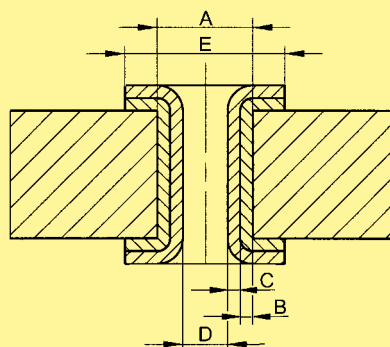

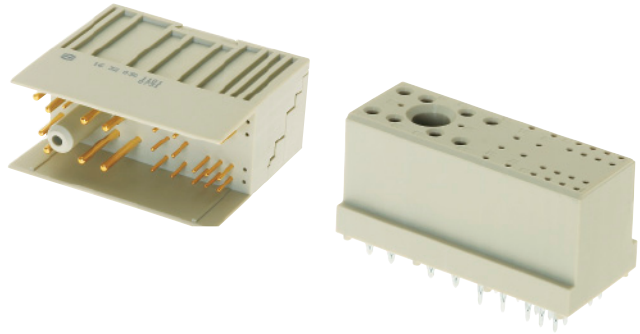

Identification	No. of contacts	Contact length [mm] termination side	Part number
Power connector for AdvancedTCA®, male	30	4.1	16 32 030 1101 000
	34	4.1	16 32 034 1101 000
Power connector for AdvancedTCA®, female	30	5.3	16 31 030 1201 000
	34	5.3	16 31 034 1201 000

Male connector with 30 contacts

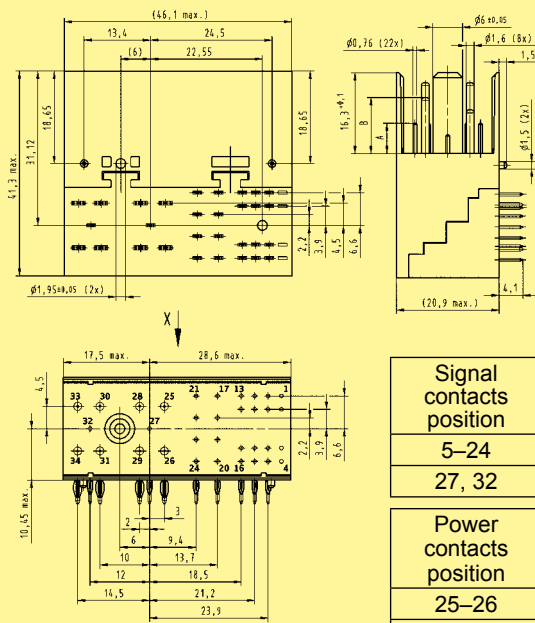

Female connector with 30 contacts

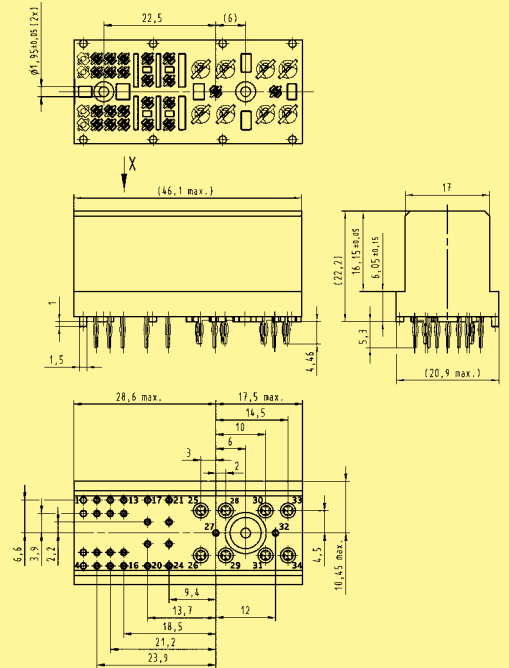

Signal contacts position	Dimension A
5–24	6.1
27, 32	3.8
Power contacts position	Dimension B
25–26	14.3
28–31	14.3
33	11.3
34	8.8

Board drillings

view X

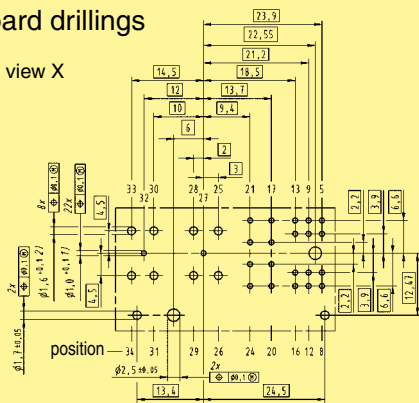

view X

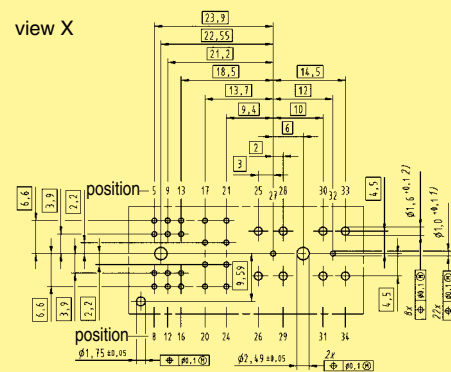

1) + 2) recommended plated through hole specification see page 14

Technical characteristics

Design according	PICMG MTCA.0 R1.0 (RoHS compliance)
Number of contacts	170
Contact spacing	0.75 mm
Clearance and creepage distance between contacts	0.1 mm min.
Working current of power contacts as defined in MTCA.0 spec.	~ 2.3 A @ 70 °C max. 30 °C temp. rise (PICMG requirement min. 1.52 A)
Test voltage	80 V _{r.m.s.}
Working voltage typically	3.3 V; 5.0 V; 12.0 V
Initial contact resistance	25 mΩ max.
Initial insulation resistance	100 MΩ min.

Nominal differential impedance 100 Ω±10 %

Max. NEXT @ 25 ps risetime	Bottom route
Adjacent	0.65 %
Basic-to-extended (diagonal)	0.60 %
Basic-to-extended (opposite)	0.73 %
Multiline (five multi-aggressor differential pairs)	2.88 % max.

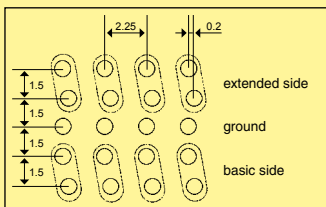

PCB library on request (PADS/Dx-Designer)
SPICE models and S-Parameter on request

Differential propagation delay	Basic side: 70 ps ± 5 ps Extended side: 70 ps ± 5 ps
Differential skew	Between basic and extended side: ±2 ps Within basic and extended side: ±2 ps

Temperature range	-55 °C ... +105 °C
Durability as per MTCA.0 spec.	200 mating cycles
Termination technique	Press-in termination
Mating force	100 N max., typically 60 - 80 N (depending on AdvancedMC™)
Withdrawal force	65 N max., typically 40 - 60 N (depending on AdvancedMC™)

Materials

Moulded parts	Liquid Crystal Polymer (LCP), UL 94-V0
Contacts	Copper Alloy
Contact surface	Pd/Ni with Au flash Au over Ni on request
Packaging	Cardboard box (other packaging on request)

Recommended plated through hole specification

	A	Drill hole-Ø	0.64±0.01 mm
	B	Cu	25 - 35 µm
Tin plated PCB (HAL)	C	Sn	5 - 15 µm
	D	Hole-Ø	0.53 - 0.60 mm
Au / Ni plated PCB	C	Ni	3 - 7 µm
		Au	0.05 - 0.12 µm
	D	Hole-Ø	0.55 - 0.60 mm
Chemical tin plated PCB	C	Sn	0.8 - 1.5 µm
	D	Hole-Ø	0.56 - 0.60 mm
Silver plated PCB	C	Ag	0.1 - 0.3 µm
	D	Hole-Ø	0.56 - 0.60 mm
OSP copper plated PCB	C	---	---
	D	Hole-Ø	0.56 - 0.60 mm
	E	Pad size	min. 0.95 mm

The press-in zone of the AdvancedMC™ connector is tested according to Telcordia/Bellcore GR 1217CORE Part7. It is approved to be used with a plated through hole according to IEC 60352-5 with a diameter of 0.55±0.05 mm (drilled hole 0.64±0.01 mm). Based on our experiences regarding the production process of the PCB manufacturer we recommend a plated through hole configuration like shown in the above spreadsheet. To achieve the recommended plated through hole diameter, it is important to specify especially the drilled hole diameter of 0.64±0.01 mm to your PCB supplier. For drillings use e.g. drill bit # 72 (0.025" ≈ 0.64 mm).

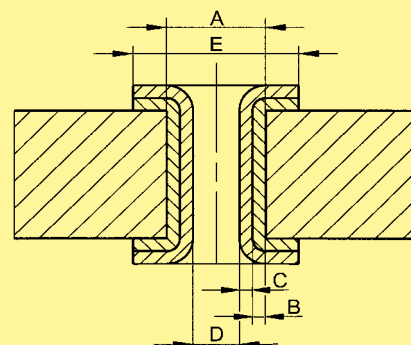

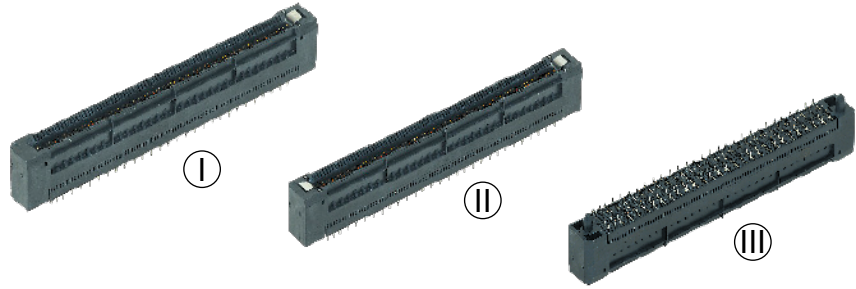

Card edge connectors, straight

Identification	No. of contacts	Contact length [mm] termination side	Part number
AdvancedMC™ connectors for MicroTCA™ with GuideSpring (I)	170	2.1	16 11 170 5202 000
with GuideSpring and protection shield (II)	170	2.1	16 11 170 5205 000
with GuideSpring and alignment peg (III)	170	2.1	16 11 170 5206 000
with GuideSpring, protection shield and alignment peg	170	2.1	16 11 170 5207 000

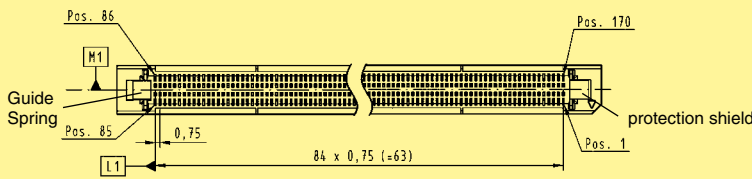
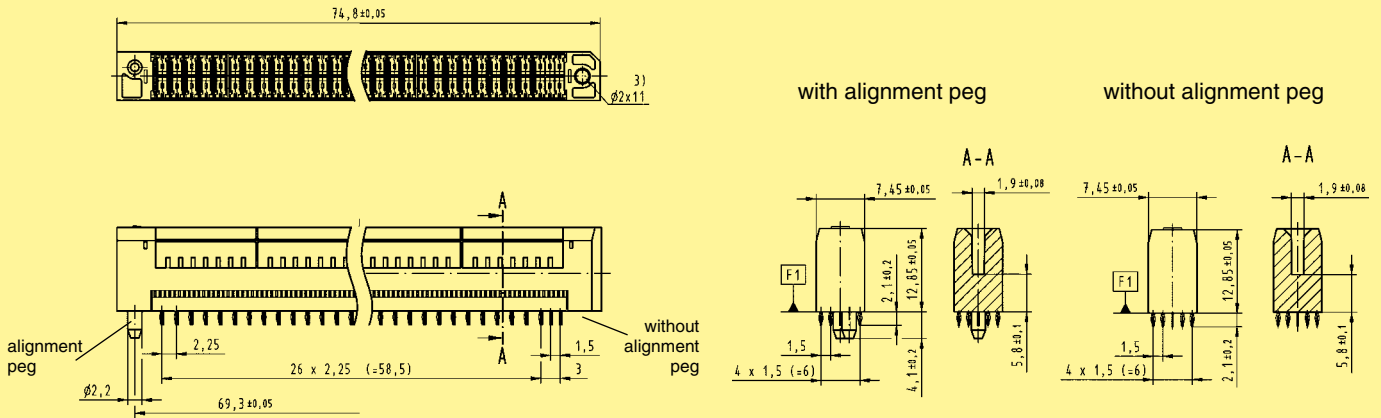

- recommended plated through hole specification see page 16
- non-metallized drillings optional: for part numbers 16 11 170 5202 000 and 16 11 170 5205 000 mandatory: for part numbers 16 11 170 5206 000 and 16 11 170 5207 000
- for optional fixing: use self-tapping screws for plastic, 2.2 x length (length = PCB thickness + min. 6.5 mm to max. 10 mm) e.g. HARTING part number 09 06 001 9974 Screwing torque references:
PCB + 6.5 mm: 20 cNm
PCB + 10 mm: 40 cNm

Board drillings (view magnified)

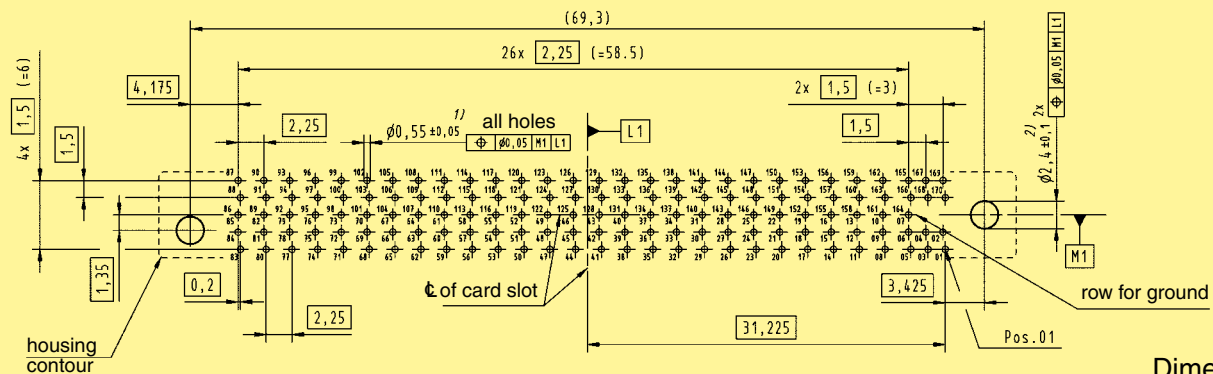

Dimensions [mm]

Technical characteristics

Design according to PICMG MTCA.0 R1.0 (RoHS compliance)

Total number of contacts: 96
 Power contacts: 24
 Signal contacts: 72

Sequential contact engagement:
 1st: Power 4–11
 2nd: Power 1–3, power 12–24
 3rd: Signal A2–H9
 4th: Signal A1

Working current:
 Power contacts: 9.3 A @ 80 % derating acc. IEC 60512 and 70 °C ambient temperature and 30 °C temperature rise
 Signal contacts: 1 A @ 80 % derating acc. IEC 60512 and 70 °C ambient temperature

Initial contact resistance:
 Power contacts: ≤ 5 mΩ
 Signal contacts: ≤ 25 mΩ

Initial insulation resistance ≥ 100 MΩ min.

Temperature range: -55 °C ... +105 °C
 Durability: 200 mating cycles

Termination technique: Press-in termination
 Mating force: 145 N max.
 Withdrawal force: 110 N max.

Derating for MicroTCA™ power contacts
 Contact loading acc. MTCA.0

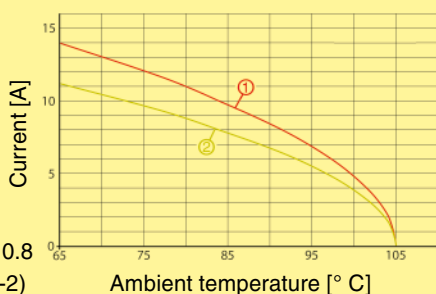

① Derating
 ② Derating @ $I_{max} \times 0.8$ (acc. IEC 60512-5-2)

Materials

Moulded parts: PBT, glass-fibre filled, UL 94-V0
 Contacts: Copper Alloy
 Contact surface:
 Power contacts: selectively gold plated
 Signal contacts: selectively Pd/Ni plated

Packaging: Tray packaging (other packaging on request)

Recommended plated through hole specification

	A	Drill hole-Ø	0.7±0.02 mm
	B	Cu	25 - 35 µm
Tin plated PCB (HAL)	C	Sn	5 - 15 µm
	D	Hole-Ø	0.60 - 0.65 mm
Au / Ni plated PCB	C	Ni	3 - 7 µm
		Au	0.05 - 0.12 µm
Chemical tin plated PCB	D	Hole-Ø	0.60 - 0.65 mm
	C	Sn	0.8 - 1.5 µm
Silver plated PCB	D	Hole-Ø	0.60 - 0.65 mm
	C	Ag	0.1 - 0.3 µm
OSP copper plated PCB	D	Hole-Ø	0.60 - 0.65 mm
	C	---	---
	E	Pad size	min. 1.0 mm

The press-in zone of the MicroTCA™ power connector is tested according to Telcordia/Bellcore GR 1217CORE Part7. It is approved to be used with a plated through hole according IEC 60352-5 with a diameter of $0.60^{+0.05}$ mm (drilled hole $0.70^{±0.02}$ mm).

Based on our experiences regarding the production process of the PCB manufacturer we recommend a plated through hole configuration like shown in the above spreadsheet. To achieve the recommended plated through hole diameter, it is important to specify especially the drilled hole diameter of $0.70^{±0.02}$ mm to your PCB supplier.

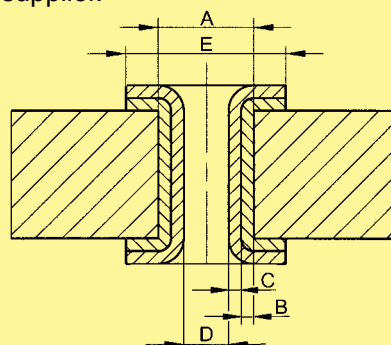

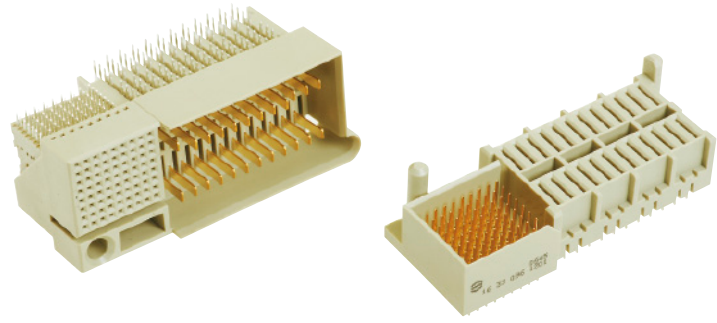

Identification	No. of contacts	Contact length [mm] termination side	Part number
Power output connectors for MicroTCA™			
module version	96	2.8	16 34 096 1101 000
backplane version	96	3.7	16 33 096 1201 000

Module version

Backplane version

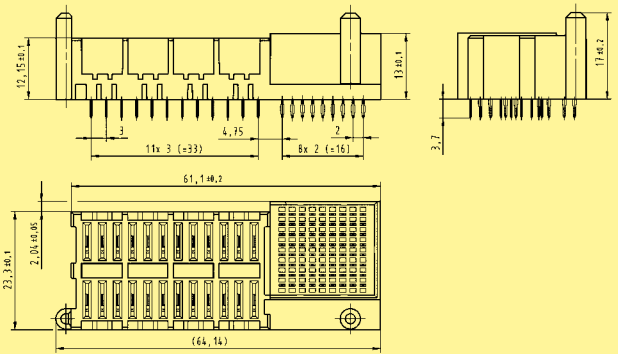
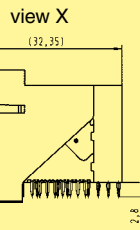
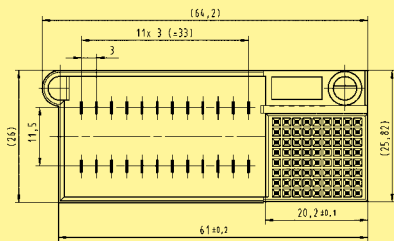

Board drillings

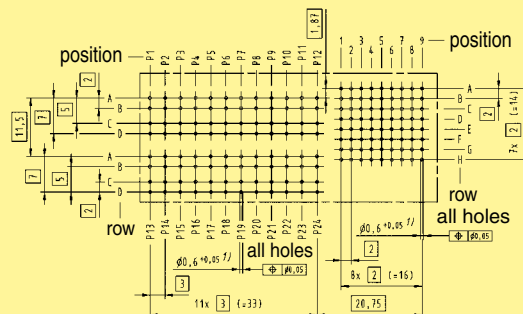
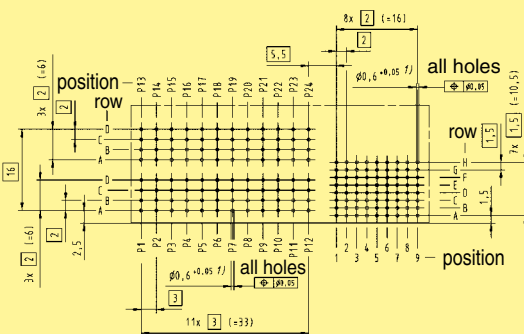

1) recommended plated through hole specification see page 18



Identification

Part number

MicroTCA™ Protection Block

16 79 000 0010 000

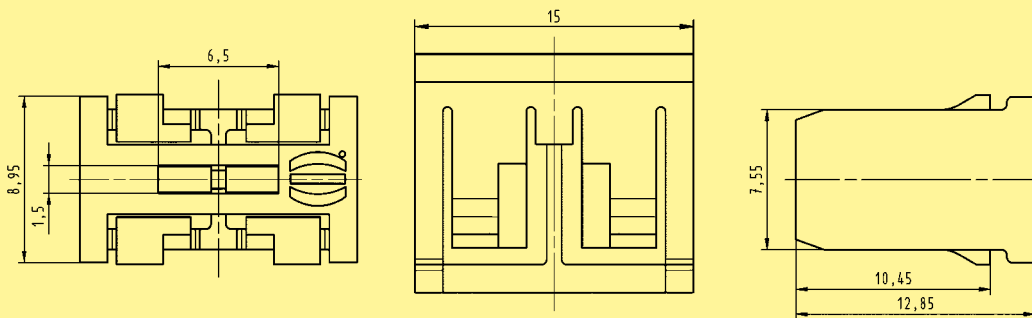

The MicroTCA™ specification defines modules with the option of multiple mating interfaces like the MCH module for system management and switching. There are four different pitches defined for the module interfaces and the backplane connectors respectively, the basic unit is called horizontal pitch (HP) and is 5.08 mm (0.2 inch).

Compact-Size	3 HP	15.24 mm
Mid-Size	4 HP	20.32 mm
Full-Size	6 HP	30.48 mm
MCH	1.5 HP	7.62 mm

Any MCH (or other multiple mating interface modules) with more than two mating interfaces (2x MCH-pitch 1.5 HP = Compact-Size pitch 3 HP) could unintentional mate with connectors of the adjacent slot or could be plugged into the wrong slot. Even though the pin-assignment and e-keying for the MCH is defined, it can cause system failures or even destroy hardware if a MCH is inserted into two adjacent AMC Compact-Size slots. For other multiple mating interface modules, this situation is even worse, because neither e-keying nor pin assignment is specified in MTCA.0.

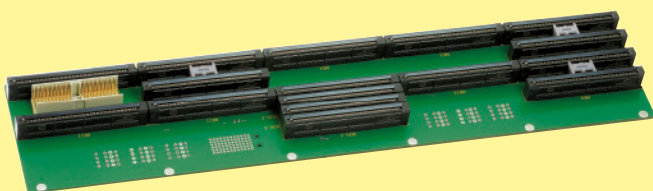

MicroTCA™ backplane with protection blocks

To prevent errors in case of misinsertion, MTCA.0 R1.0 chapter 2.13 outlines protection blocks that occupy the space between two adjacent connectors in a Compact-Size slot. Furthermore this protection block can be used for keying functions of multiple mating interface modules.

HARTING designed a protection block fully independent of the backplane and sub rack design. The HARTING protection block is clipped between two connectors, hence no fixing features (holes, clips...) need to be designed into the backplane or the sub rack mechanics. The assembly is done quick and easy by hand. It can even be installed easily after the backplane is mounted with a simple flat-head screwdriver, an easy removal is possible in a similar way. The keying block can be placed into four different positions, hence a keying of multitongue modules by using tongues with a cutout is possible.

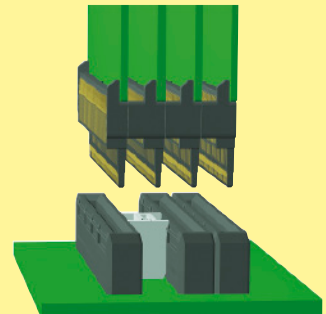

The free space between the backplane connectors is occupied by the protection block

The PICMG specification AMC.0 defined a card edge with gold pads as the mating interface for the AdvancedMC™ module.

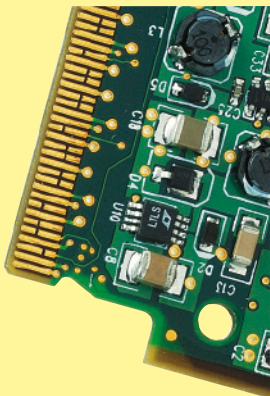

As already explained in the chapter “con:card+”, it is very difficult for a PCB manufacturer to produce the tight tolerances required for the AdvancedMC™ module card edge in a consistent process. Furthermore, the quality of the gold pads is only specified in general terms.

Replacing the PCB gold pads with a connector eliminates certain drawbacks of the card edge connection. The HARTING Plug Connector offers the following advantages:

- **Controlled quality of both mating sides**
- **Small dimensional tolerances**
- **Defined hard gold surface**
- **Reduced mating forces**
- **Allows use of thicker PCBs**
- **Standard reflow solder process**
- **Cost savings are possible**

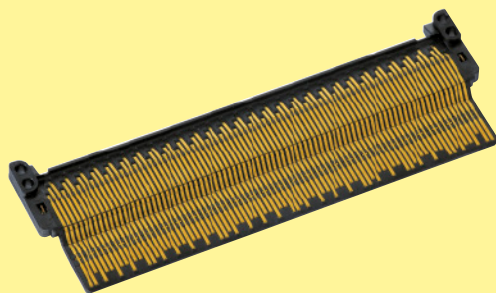

Controlled quality of both mating sides

The major advantage is that a solid contact with a band plated surface mates with the backplane connector. The connection is no longer made directly from the card edge to the backplane connector but instead indirectly via a module connector approved from one source. The AdvancedMC™ module with a Plug Connector is still within the dimensional range of the PICMG AMC.0 specification and is fully mating compatible with AdvancedMC™ card edge connectors. Consequently the Plug Connector can be used in both MicroTCA™ and ATCA® environments.

Small dimensional tolerances

The injection moulding process is much more precise than the PCB production process. While the AMC.0 specification defines a PCB width tolerance of 0.1 mm,

the moulding process has a dimensional tolerance less than 0.03 mm. The lead-in chamfer is milled for the PCB but is realized in the connector as a smooth moulded plastic chamfer. Compared with the rough surface of a PCB chamfer with exposed glass fibre, the smooth Plug chamfer avoids abrasion of the backplane connector contact surface.

Defined hard gold surface

The AMC.0 specification defines hard gold to be on the PCB pads. However a common and unique definition of hard gold does not exist today. Additionally, the interruptions of the gold pads (which are necessary for the hot-swap ability) require a selective hard gold process. This is a complex process which is relatively expensive, so commonly just chemical gold with insufficient surface thickness is used. As a result, there are significant differences in the durability of the gold and the surface structure on the modules which are currently available.

The contacts of the HARTING AdvancedMC™ Plug Connector are plated all-around and are manufactured in a defined band plating process with controlled quality. There are different performance levels possible as the noble finish thickness can be adapted easily to meet customer demands.

Reduced mating forces

For the module card edge, the prepads of lagging contacts are required by the Telcordia/Bellcore specification to avoid stress of the connector contact when sliding on the FR4 base material. The Plug Connector does not need prepads. The four mating steps are realized with true lagging contacts. The sophisticated design of the insulator reduces the mating forces of the module significantly.

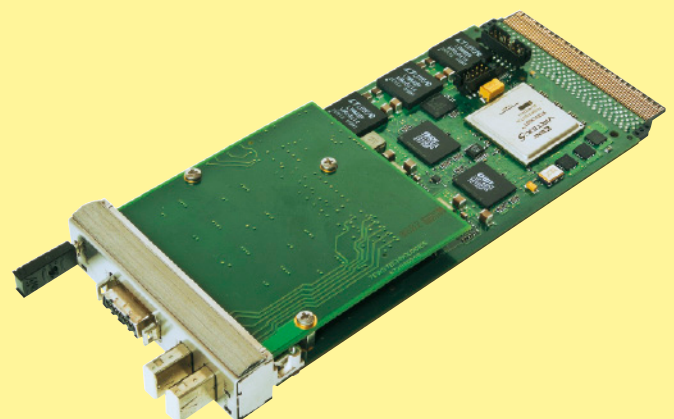

Allows use of thicker PCBs

By using a HARTING AdvancedMC™ Plug Connector, the mating interface of the module is defined by the connector instead of the PCB. This fact leads to clear advantages and provides a wider scope for the module development. The restriction of the PCB thickness of 1.6 mm +/-10% is no longer a limiting factor. A PCB

thickness of e.g. 2 mm can be used as this fits in the mechanical environment.

Standard reflow solder process

For backplanes press-fit termination is the first choice, however solder termination offers advantages for module cards. The Plug Connector is mounted to the

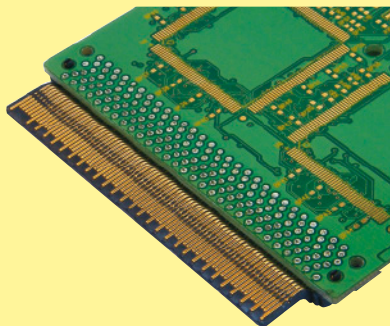

PCB through “pin-in-hole-reflow” solder technology (PIHR). It can be soldered in the same production process as the other semi finished components on the AdvancedMC™ module. Optionally, the Plug Connector

can be delivered with a pick-and-place-pad for automatic assembly.

Another advantage of this mechanically stable technology is, that the connector can be replaced. This can avoid the cost of scrapping a module if the mating interface is damaged during handling.

Cost savings are possible

By offering so many different advantages during the manufacturing process, the use of HARTING Plug Connectors also contributes to keeping costs down. Selective plating increases the cost of producing gold

pads. Tight tolerance specifications also cause a large number of rejects. The beveled PCB edge is another critical area, because damage can occur to the contact pads.

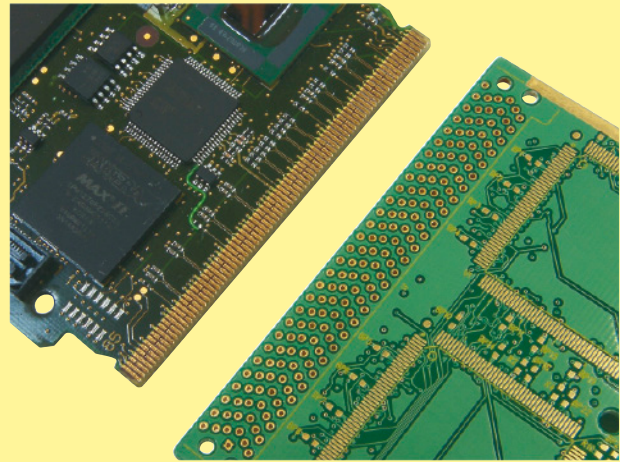

A simple board layout with through-holes is sufficient for the HARTING Plug, and these boards can be produced inexpensively and with excellent quality control, thus reducing the number of rejects. Furthermore the cost of a reject can be high if a defective PCB edge is not detected until the board is populated with expensive components. A HARTING Plug on a module can be replaced easily, reducing scrapping costs.

Mounting direction

The HARTING Plug Connector is available in two versions. The difference is the mounting direction, i. e. the side of the AdvancedMC™ module PCB on which the Plug Connector is assembled.

Basic side

The so called basic side refers to the component side 1 as defined in the AMC.0 specification (pins 1 to 85). The main components are mounted on the basic side (sometimes also called top side).

During the manufacturing process, a Plug Connector that is mounted from the basic side can be soldered in the same assembly step as the other large components.

Extended side

The so called extended side refers to the component side 2 as defined in the AMC.0 specification (pins 86 to 170).

A Plug Connector mounted on the extended side is “hanging” at the bottom side of the AdvancedMC™ module.

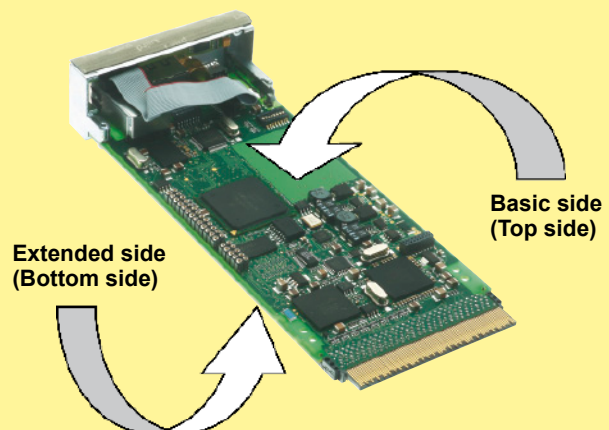

This picture shows an AdvancedMC™ module with a Plug Connector mounted on the extended side.

The footprint of a Plug Connector for the basic side is different than that for the extended side. The connectors are not interchangeable. Due to advantages in the assembly of the connector, the basic side version is preferable.

For an MCH stack, only connectors having the same mounting direction can be stacked (see page 26).

Design according PICMG MicroTCA.0 R1.0
PICMG AMC.0 R2.0
(RoHS compliance)

Number of contacts 170
Contact spacing 0.75 mm
Clearance and creepage distance between contacts 0.1 mm min.

Working current of power contacts as defined in AMC.0 spec., tested with HARTING MicroTCA™ backplane connector ~ 2.4 A @ 70 °C
max. 30 °C temp. rise
(PICMG requirement min. 1.52 A)

Test voltage 80 V_{r.m.s.}
Working voltage typically 3.3 V; 5.0 V; 12.0 V

Initial contact resistance 25 mΩ max.
Initial insulation resistance 100 MΩ min.

Nominal differential impedance 100 Ω ± 10 %

Max. crosstalk @ 25 ps risetime	Bottom route
Adjacent	0.5 %
Basic-to-extended (diagonal)	0.2 %
Basic-to-extended (opposite)	0.7 %
Multiline (five multi-aggressor differential pairs)	2.1 % max.

Propagation delay
Long contact side: 152 ps / 147 ps
Short contact side: 121 ps / 129 ps

Skew within differential pairs
Long contact side: 5 ps
Short contact side: 8 ps

Temperature range during reflow soldering -55 °C ... +105 °C
220 °C for 2 minutes
270 °C max. short-term

Durability as per AMC.0 specification 200 mating cycles in total

Termination technique Solder termination (Pin in Hole Intrusive Reflow)

Pick-and-place-weight < 7 g

Mating force 100 N max., typically 40 - 70 N
(depending on backplane connector)

Withdrawal force 65 N max., typically 30 - 50 N
(depending on backplane connector)

The mating and withdrawal force is highly depending on the mating half connector, but typically only 50 % to 70 % of the mating force of a PCB card edge.

Materials

Moulded parts Liquid Crystal Polymer (LCP), UL 94-V0

Contacts Copper alloy

Contact surface Au over Ni

Packaging Tray packaging (other packaging on request)

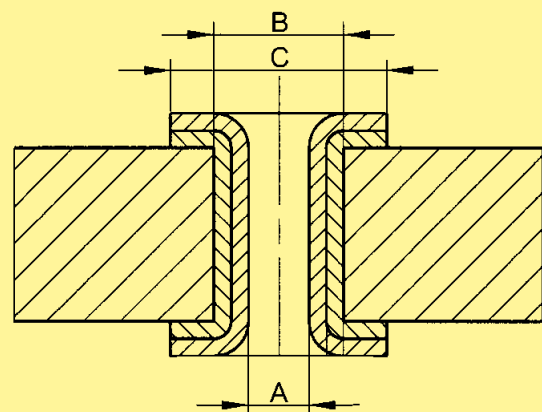

Plated through hole recommendations

A	Plated hole-Ø	0.55±0.05 mm
B	Drill hole-Ø	0.65±0.01 mm
C	Pad size	0.95 mm

Stencil recommendation (for basic side mounting)

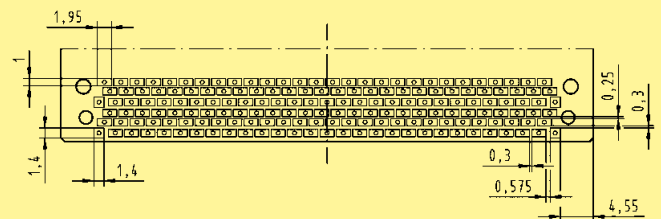

Each termination requires a solder paste volume of 0.5 mm³. Since the stencil can only provide fractions of this volume (0.29 mm³ at 0.15 mm stencil thickness), the remaining solder paste must be pressed into the plated through hole. For a nominal AMC card (1.6 mm PCB thickness, 0.55 mm plated hole diameter) the paste must penetrate the hole by 0.9 mm.

Plug Connector for AdvancedMC™ modules

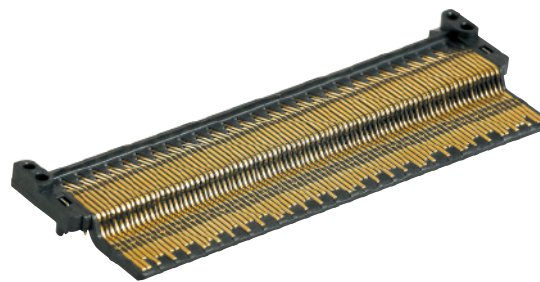

For mounting on basic side

Identification	No. of contacts	Part number
AdvancedMC™ Plug Connector for basic side mounting	170	16 23 170 1301 000
AdvancedMC™ Plug Connector for basic side mounting with nozzle pad for pick and place assembly	170	16 23 170 1302 000

AdvancedMC™ Plug Connector for basic side mounting

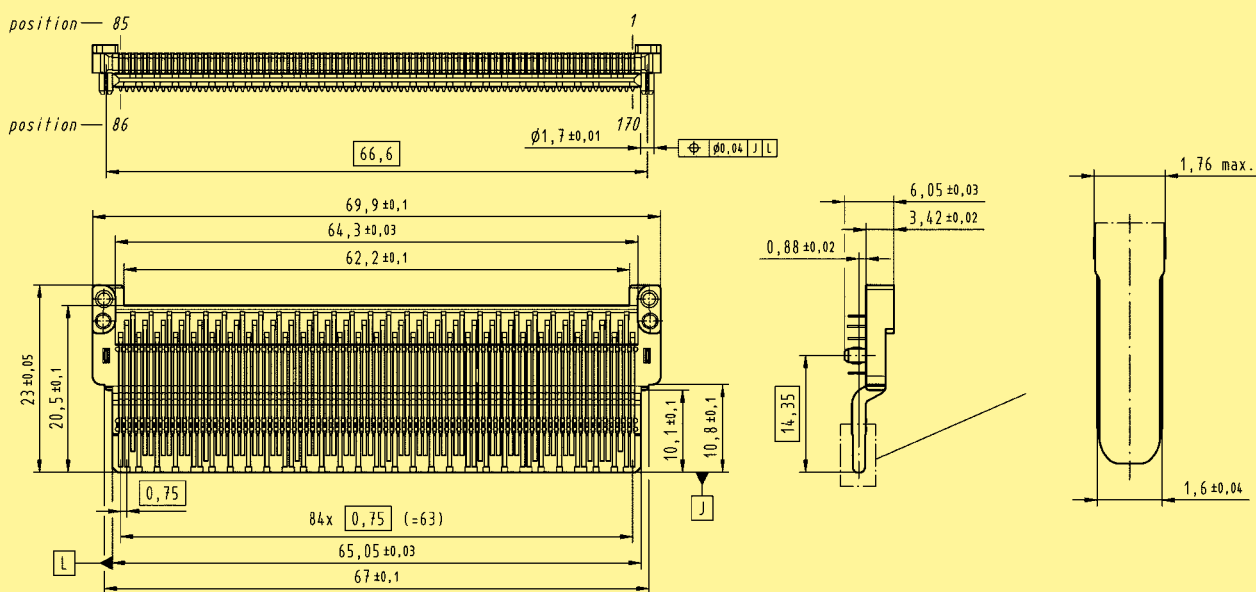

Board drillings (view of the basic side / component side 1)

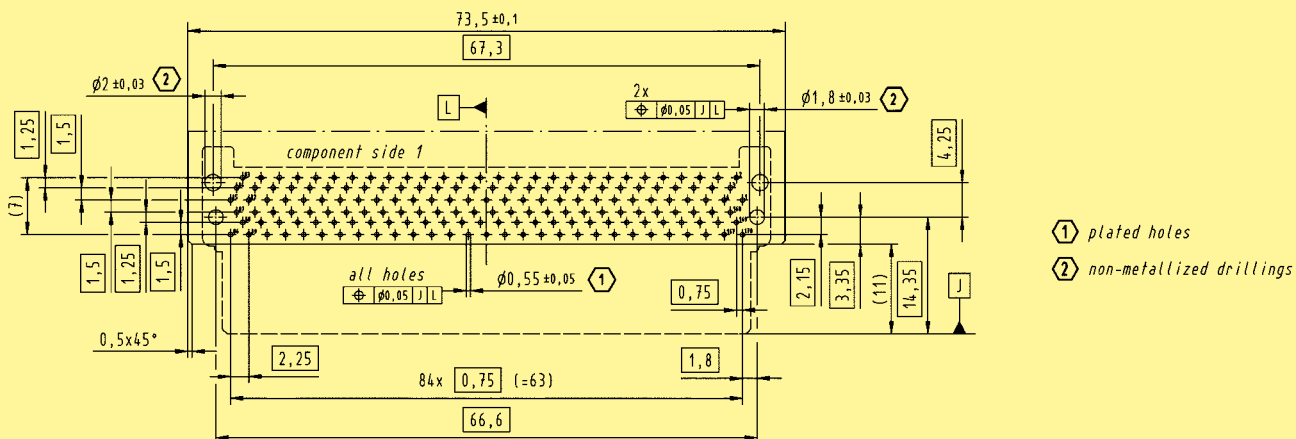

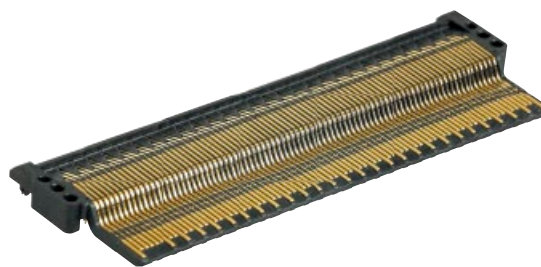

For mounting on extended side

Identification	No. of contacts	Part number
AdvancedMC™ Plug Connector for extended side mounting replacement of former part number 16 21 170 1301 000	170	16 21 170 1303 000
AdvancedMC™ Plug Connector for extended side mounting with nozzle pad for pick and place assembly replacement of former part number 16 21 170 1302 000	170	16 21 170 1304 000

AdvancedMC™ Plug Connector for extended side mounting

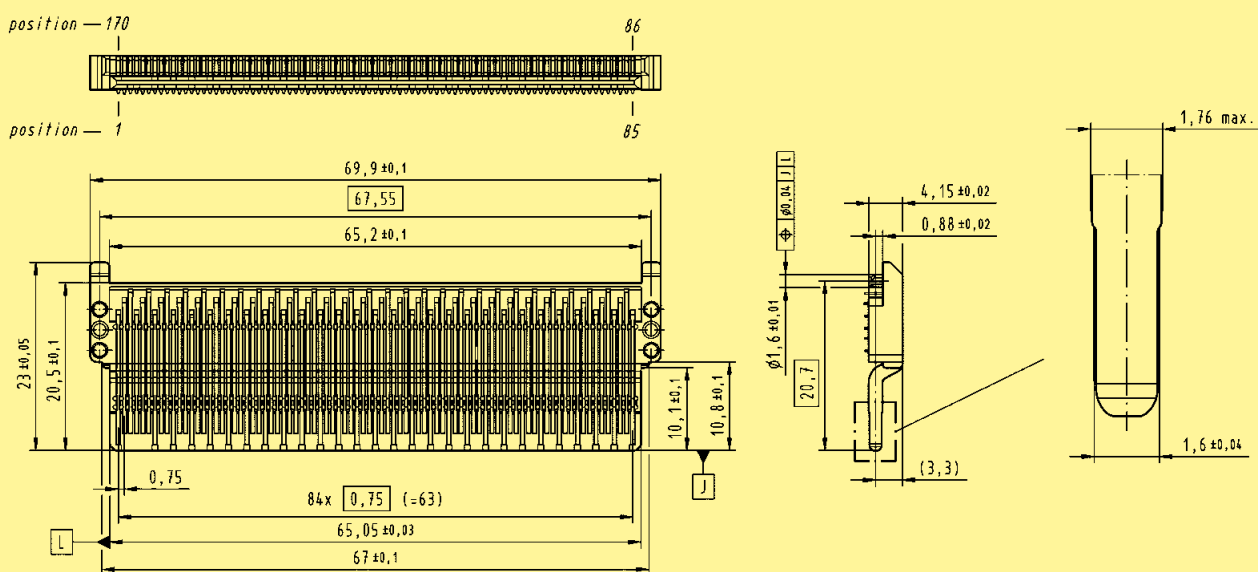

Board drillings (view of the extended side / component side 2)

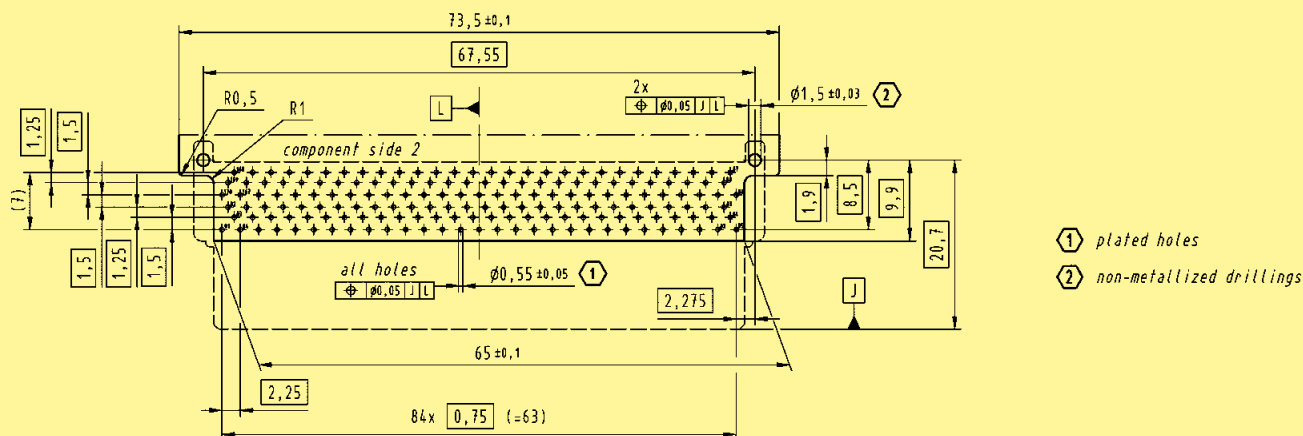

Dimensions [mm]

An important component of a MicroTCA™ system is the “MicroTCA™ Carrier Hub”, abbreviated MCH. The main functions of an MCH module are hardware platform management and the management of the fabric connectivity. Since the MCH module requires many more connections than a standard AdvancedMC™ module, an MCH may have up to 4 mating tongues each with 170 contacts.

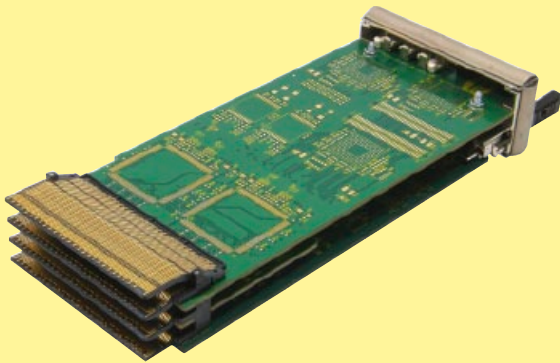

The MTCA.0 specification recommends the use of a special Plug Connector to reduce the insertion force of the module and to solve the tolerance stack-up problem between the multiple tongues and the backplane connectors.

The HARTING Plug Connector system consists of three different Plug Connectors. The **AdvancedMC™ Plug** is required for an MCH module and is always used in the MCH1-slot. Furthermore it can be used for any conventional AdvancedMC™ module to replace the pcb gold pads.

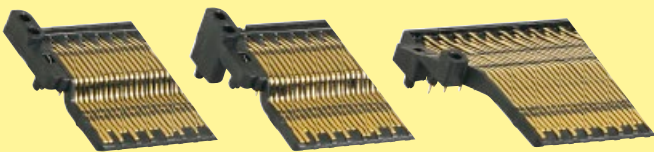

AdvancedMC™ Plug, MCH Plug, Piggyback Plug

If more than one mating tongue is needed, the **MCH Plug Connector** is mated with the backplane MCH connectors 2 and 3 depending on the MicroTCA™

configuration. Compared to the AdvancedMC™ Plug, the MCH Plug insulator has standoffs ensuring the correct distance for the slot width between two tongues or backplane connectors respectively. The MCH and AdvancedMC™ Plugs have different contact staggering on the basic side, the extended side is equal.

The **Piggyback Plug Connector** is designed for the MCH4 slot, but the connector itself is soldered on the PCB3. For a MicroTCA™ system with more than 6 AdvancedMC™ modules using the switched fabric fat pipe, an MCH module with 4 mating tongues must be used. In general the switched fabric is located only on the PCB3, so a high-speed connection is needed between the MCH4 slot and the PCB3.

To build a connector stack for two, three or four mating tongues, the HARTING Plug Connectors are mounted like building blocks via pegs and the holes on the adjacent Plugs. For additional mechanical stability, the connector stack is fixed using metal stacking pins. The complete connector stack can be installed easily without any special tooling.

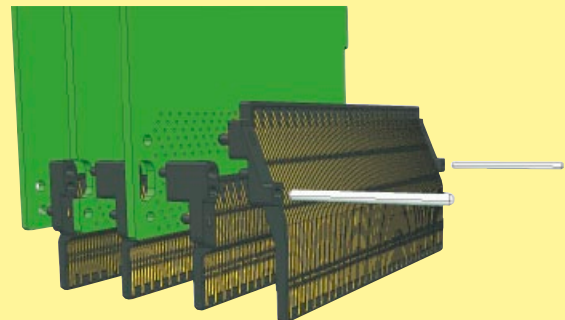

Exploded view of an MCH stack with four tongues including Piggyback Plug

As with the AdvancedMC™ Plug, HARTING offers the Plug Connectors for MCH modules in versions for basic side or extended side mounting. Only connectors with the same mounting direction can be stacked together. The Piggyback Plug is only available as basic side version, therefore for a MCH module with four tongues, the basic side version is preferred.

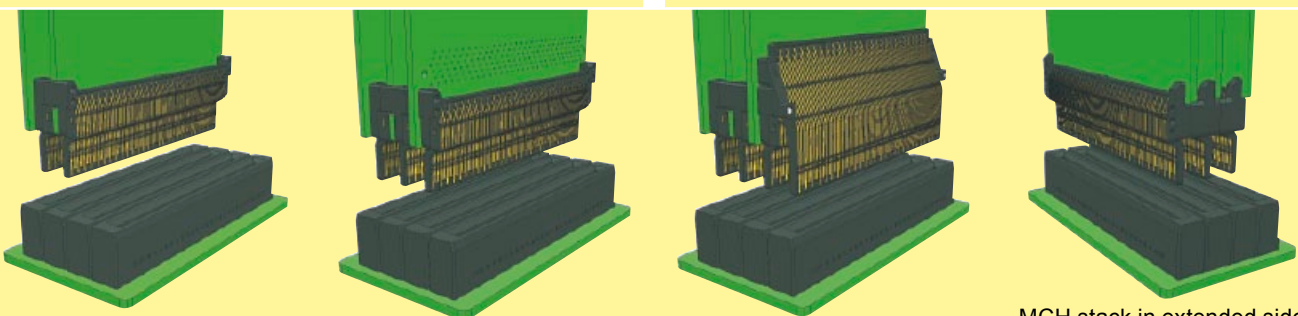

MCH stacks in basic side version with 2, 3 and 4 tongues

MCH stack in extended side version

Plug Connectors for MCH modules

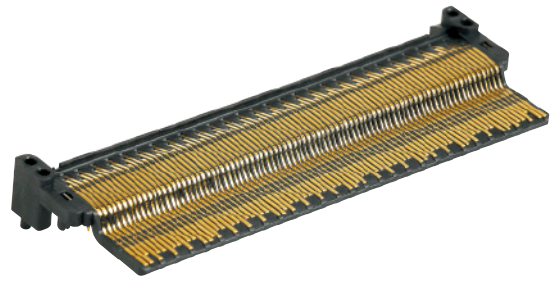

For mounting on basic side

Identification	No. of contacts	Part number
AdvancedMC™ Plug Connector for basic side mounting	170	16 23 170 1301 000
AdvancedMC™ Plug Connector for basic side mounting with nozzle pad for pick and place assembly	170	16 23 170 1302 000
MCH Plug Connector for basic side mounting	170	16 24 170 1301 000
MCH Plug Connector for basic side mounting with nozzle pad for pick and place assembly	170	16 24 170 1302 000
AdvancedMC™ – MCH Plug stacking-pin for basic side mounting		
double length (for two stacked plugs) 11 mm		16 79 000 0017 000
triple length (for three stacked plugs) 18.5 mm		16 79 000 0019 000
quad length (for four stacked plugs) 22.5 mm		16 79 000 0020 000

MCH Plug Connector for basic side mounting

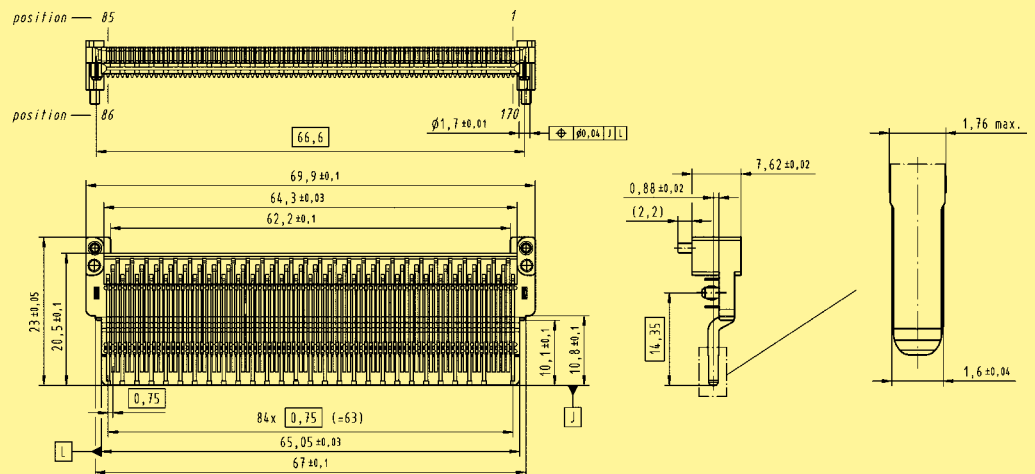

Board drillings (view of the basic side / component side 1)

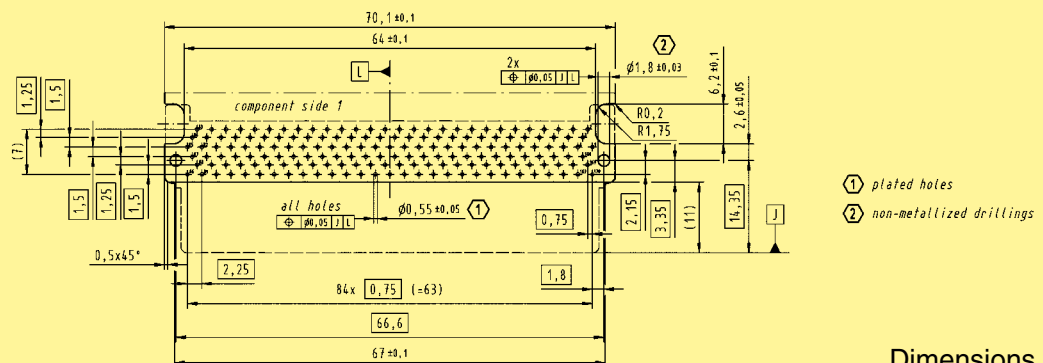

Dimensions [mm]

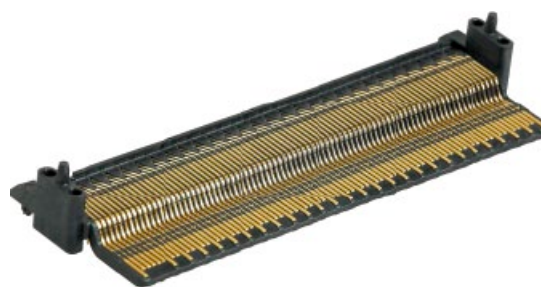

For mounting on extended side

Identification	No. of contacts	Part number
AdvancedMC™ Plug Connector for extended side mounting replacement of former part number 16 21 170 1301 000	170	16 21 170 1303 000
AdvancedMC™ Plug Connector for extended side mounting with nozzle pad for pick and place assembly replacement of former part number 16 21 170 1302 000	170	16 21 170 1304 000
MCH Plug Connector for extended side mounting replacement of former part number 16 22 170 1301 000	170	16 22 170 1303 000
MCH Plug Connector for extended side mounting with nozzle pad for pick and place assembly replacement of former part number 16 22 170 1302 000	170	16 22 170 1304 000
AdvancedMC™ – MCH Plug stacking-pin for extended side mounting		
double length (for two stacked plugs) 11.5 mm		16 79 000 0006 000
triple length (for three stacked plugs) 19 mm		16 79 000 0007 000
quad length (for four stacked plugs) 26.5 mm		16 79 000 0008 000

MCH Plug Connector for extended side mounting

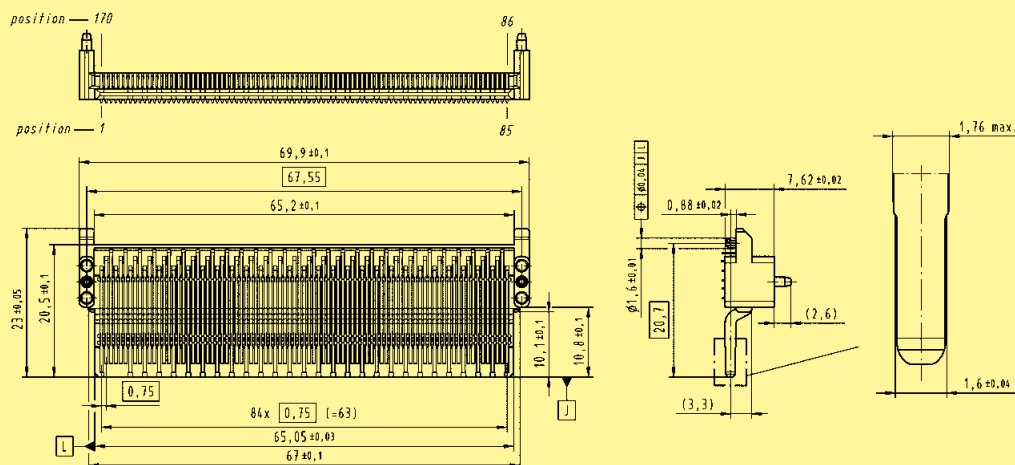

Board drillings (view of the extended side / component side 2)

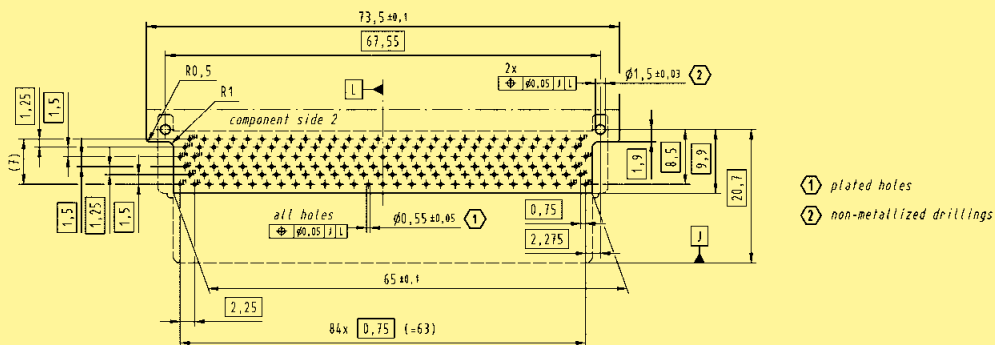

Dimensions [mm]



Identification	No. of contacts	Part number
MCH Piggyback Plug Connector applicable only in basic side mounting configuration	170	16 25 170 1301 000

MCH Piggyback Plug Connector

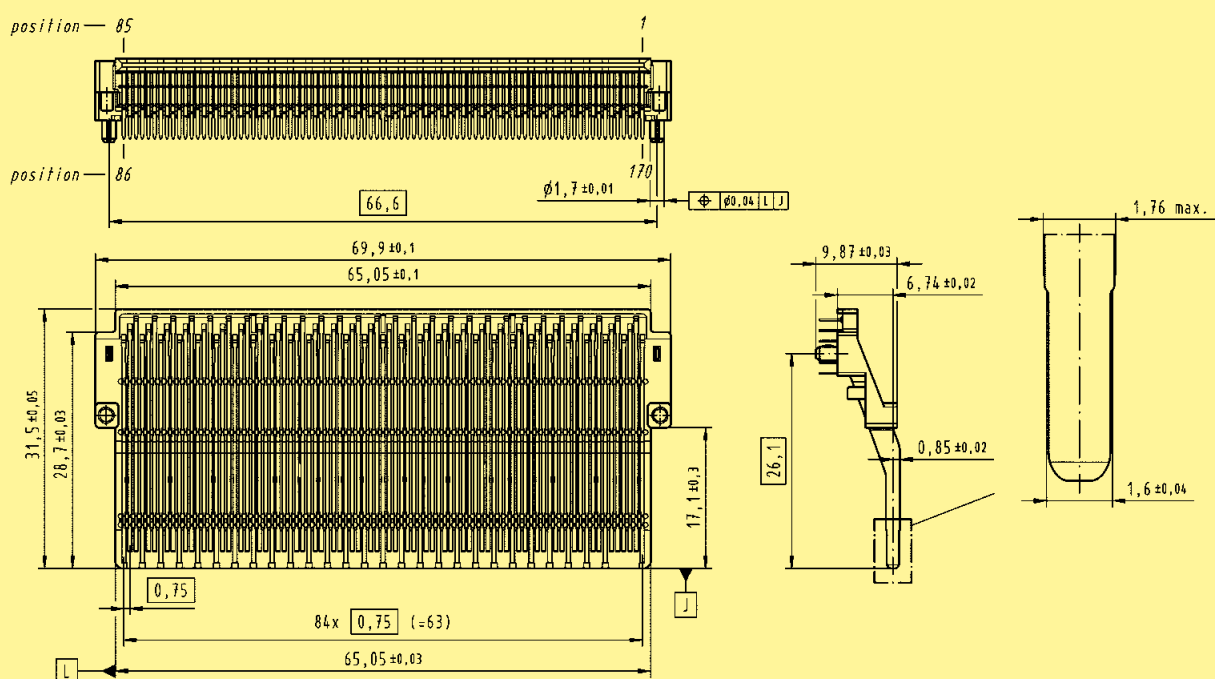

Board drillings (view of the basic side / component side 1)

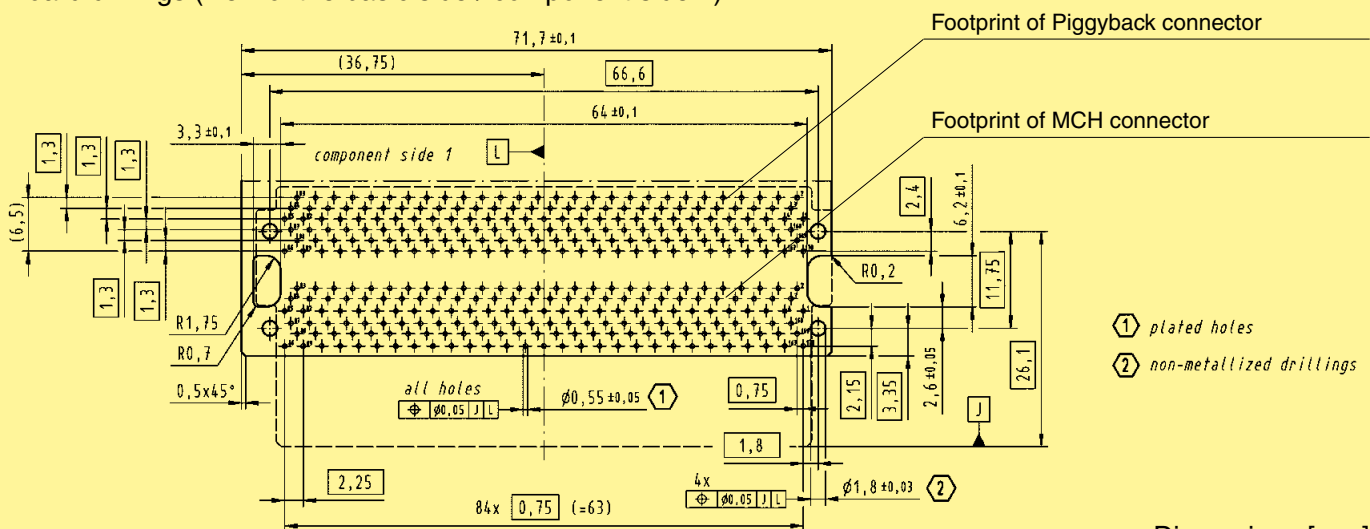

- ① plated holes
- ② non-metallized drillings

Dimensions [mm]

For a reliable and safe press-in process HARTING has developed a special tooling system. Each tooling is adapted to the special requirements of the individual connector range, thus a good handling and quick adjustment is guaranteed.

Identification	Part No.	Drawing
Top tool for AdvancedTCA® B+	16 99 000 0001 000	<p>Top tool for AdvancedTCA® B+</p>
Bottom tool for AdvancedTCA® B+	16 99 000 0002 000	
Top tool for MicroTCA™	16 99 000 0003 000	<p>Top tool for MicroTCA™</p>
Bottom tool for MicroTCA™	16 99 000 0004 000	
Top tool for AdvancedTCA® Power Male and female connector	02 99 000 0002	<p>Top tool for AdvancedTCA® Power and MicroTCA™ Power, module version</p>
Bottom tool for AdvancedTCA® Power Male and female connector	16 99 000 0011 000	
Top tool for MicroTCA™ Power Module version Backplane version	02 99 000 0002 16 99 000 0008 000	<p>Top tool for MicroTCA™ Power, backplane version</p>
Bottom tool for MicroTCA™ Power Module version Backplane version	16 99 000 0010 000 16 99 000 0009 000	
Removal tool for AdvancedTCA® B+	16 99 000 0005 000	<p>Removal tool for AdvancedTCA® B+</p>
Removal tool for MicroTCA™	16 99 000 0007 000	
Repair pliers for MicroTCA™	16 99 000 0006 000	<p>Repair pliers for MicroTCA™</p>
Removal tool for MCH Plug stacking-pins for extended side version	16 99 000 0012 000	

Identification	Part No.	Drawing	Dimensions in mm
Hand bench press	09 99 000 0201		<p>Technical characteristics</p> <p>Working stroke 25 mm</p> <p>Press force 15 kN max.</p> <p>Hole ϕ in the ram ϕ 10 mm</p> <p>Net weight approx. 23 kg</p>
Pneumatic press 40 kN	09 99 000 0282		<p>Technical characteristics</p> <p>Total stroke 48 mm</p> <p>Working stroke 0-6 mm</p> <p>Press force 40 kN max.</p> <p>Air pressure 6 bar</p> <p>Hole ϕ in the ram ϕ 10 mm</p> <p>Net weight 136 kg</p> <p>Power supply 110 V / 220 V AC</p>
CPM <i>prestige</i>	09 89 040 0000		<p>Technical characteristics</p> <p>Drive electro-mechanical, servo</p> <p>Press-in force 100 kN</p> <p>max. PCB dimensions 600 x 1000 mm</p> <p>Floor space 1200 x 1150 mm</p> <p>Weight 980 kg</p> <p>Power supply 208 / 380 / 400 / 415 V</p> <p>Consumption < 1 kW</p> <p>Colour on request</p>
Adaptor for height compensation ¹⁾	09 99 000 0279		
Guide frame with base plate Standard type for PCB size x = 123,5 - 309,5 mm	09 99 000 0244		
Long type ²⁾ for PCB size x = 123,5 - 668,5 mm	09 99 000 0261		
Base plate	09 99 000 0255		

¹⁾ suitable for 09 99 000 0282 and all CPM machines
²⁾ not suitable for hand bench press

HARTING offers signal integrity support to the end customers. We provide simulation models and evaluation kits with our products for signal integrity investigations. The evaluation kits are assembled with SMA's to connect them directly with the measurement instruments. The benefit is that the customer saves time and costs for pre-evaluation of the connector. We offer test boards suitable for the connector evaluation itself and have built reference backplanes and test cards for measurements within applications like VME, CompactPCI®, AdvancedTCA® and MicroTCA™. Reference structures and well established measurement techniques allow a full de-embedding of the propagation characteristics of the interconnect itself for test and verification. Furthermore we developed several high-speed test backplane with different connector areas and PCB design topologies.

We can provide footprint and routing recommendations for our products. A variety of testboards, simulation models and further technical data for different products are available on request.

HARTING is also an active member in standardization groups like VITA, PICMG, OBSAI and supports sub-committees for new interconnect solutions. We are in close cooperation with customers, universities and industrial partners for research activities.

Signal integrity capabilities

- Simulation and modeling
- Measurement and verification
- Test fixture & reference backplane design
- Design-in support

Simulation and modeling

Capability to perform full 3D-FEM simulations of the CAD-geometry with different well established tools like CST Microwave Studio and Ansoft HFSS. Post-processing of the data for field-distribution and full S-parameter and time-domain analysis within the software packages themselves and additional Matlab tools.



For SPICE-modeling, impedance calculation and field distribution analysis of the geometry S-parameter models are used in combination with static 3D-FEM, 2D-FEM and planar field solvers depending on the desired bandwidth of the signal. These models are used as library parts for channel simulations including particular chip, trace, vias and connector subcircuits. Eye-diagram, S-parameter and waveform analysis of the entire channel are performed with tools like HSPICE and ADS (Advanced Design System).

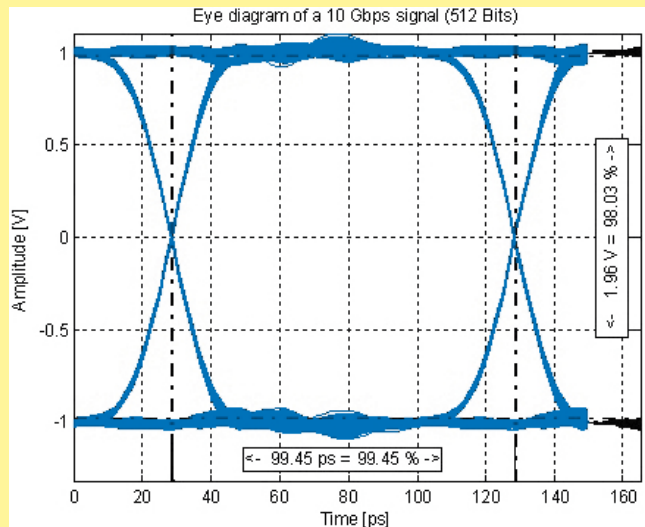
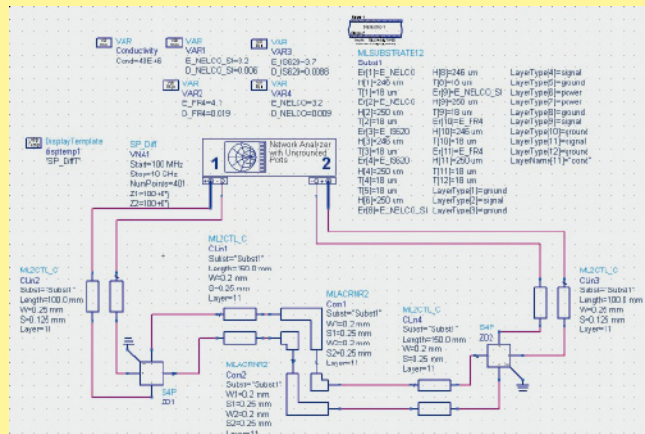

Time-domain measurements

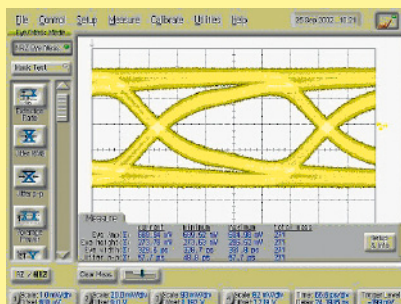
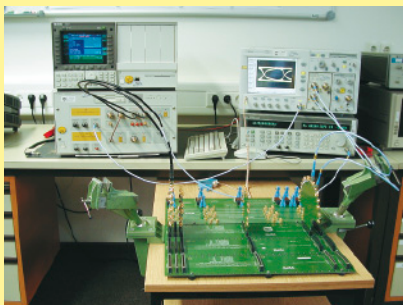

Parameters:

- Characteristic impedance
- Propagation delay
- Rise time degradation
- Reflection
- Crosstalk
- Eye-diagram and mask-test
- Bit-error rate testing (BERT) up to 12.5 Gbps per differential line

Frequency-domain measurements

Parameters:

- 4 port S-parameter analysis (up to 40 GHz)
- Insertion- and return loss, crosstalk, VSWR
- Fourier-transformation, gating, error-location
- PLTS software to calculate time-domain data, eye-diagrams, etc.

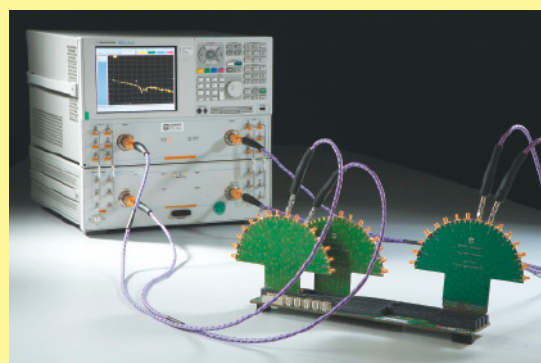

Test fixture & reference backplane design



Design-in support

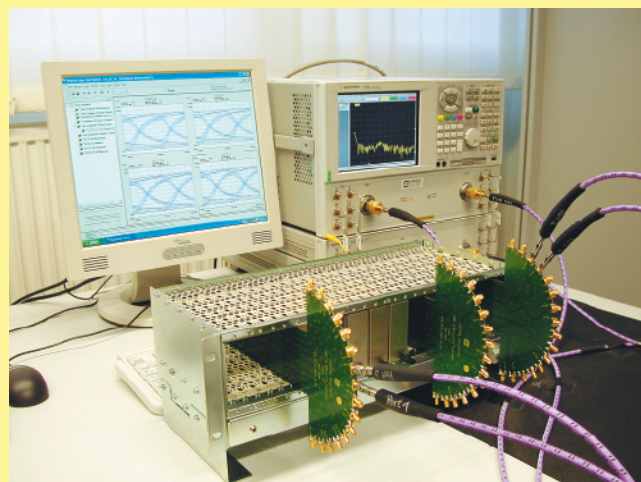

- Customized PCB design close to the real application
- Footprint and routing recommendations
- Full measurement characterization and test report
- Simulation models

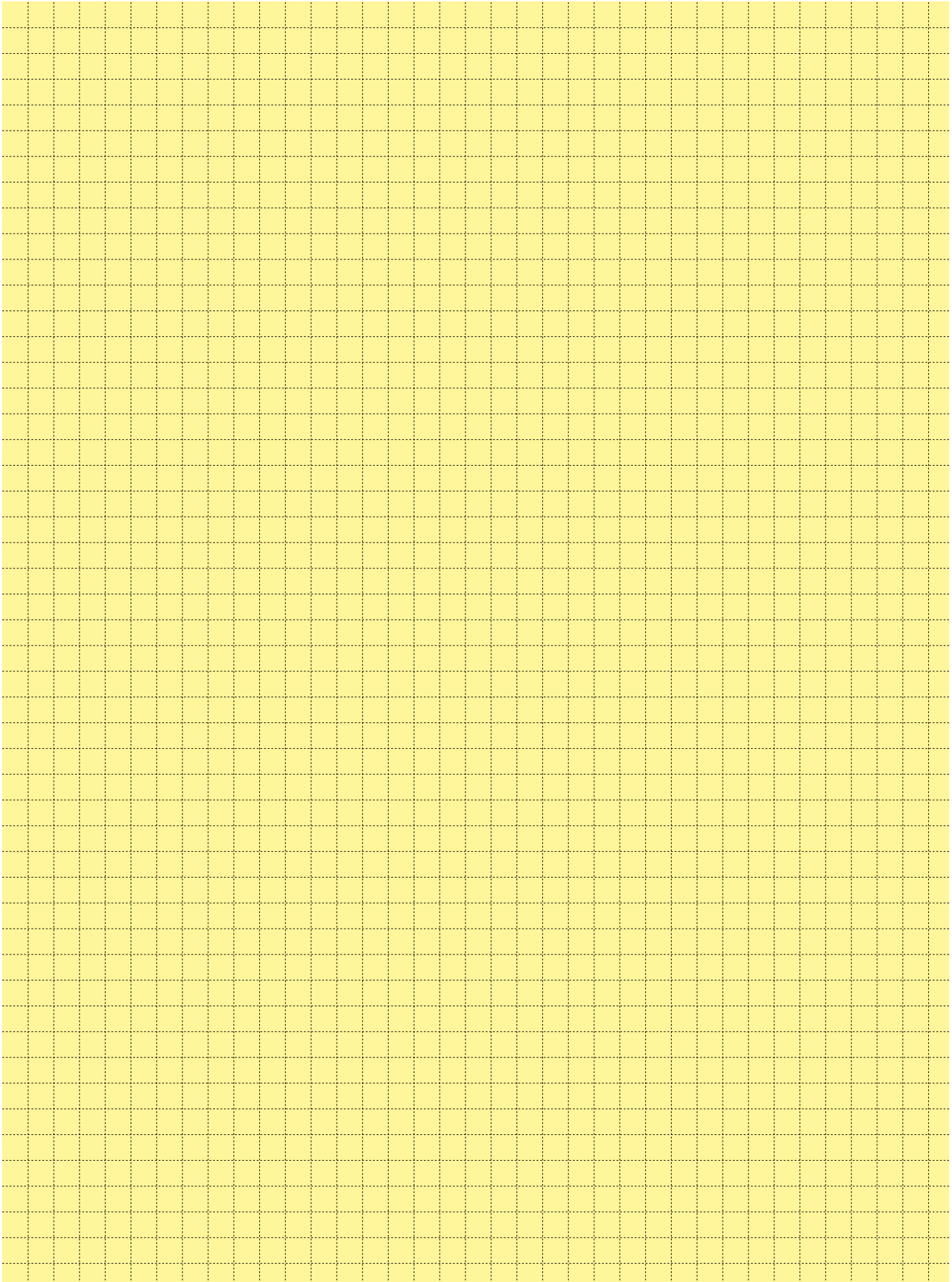

Part No.	Page	Part No.	Page	Part No.	Page	Part No.	Page
02 99 000 0002	30	16 21 170 1301 000	25	16 31 030 1201 000	15	16 99 000 0001 000	30
		16 21 170 1301 000	28	16 31 034 1201 000	15	16 99 000 0002 000	30
		16 21 170 1302 000	25			16 99 000 0003 000	30
		16 21 170 1302 000	28			16 99 000 0004 000	30
		16 21 170 1303 000	25			16 99 000 0005 000	30
09 06 001 9974	17	16 21 170 1303 000	28	16 32 030 1101 000	15	16 99 000 0006 000	30
		16 21 170 1304 000	25	16 32 034 1101 000	15	16 99 000 0007 000	30
		16 21 170 1304 000	28			16 99 000 0008 000	30
09 89 040 0000	31			16 33 096 1201 000	19	16 99 000 0009 000	30
		16 22 170 1301 000	28			16 99 000 0010 000	30
		16 22 170 1302 000	28			16 99 000 0011 000	30
09 99 000 0201	31	16 22 170 1303 000	28	16 34 096 1101 000	19	16 99 000 0012 000	30
09 99 000 0244	31	16 22 170 1304 000	28				
09 99 000 0255	31					98 40 000 0401	6
09 99 000 0261	31					98 40 000 0405	6
09 99 000 0279	31			16 79 000 0006 000	28		
09 99 000 0282	31	16 23 170 1301 000	24	16 79 000 0007 000	28		
		16 23 170 1301 000	27	16 79 000 0008 000	28		
		16 23 170 1302 000	24	16 79 000 0010 000	20		
		16 23 170 1302 000	27	16 79 000 0017 000	27		
16 04 170 5104 000	13			16 79 000 0019 000	27		
16 04 170 5106 000	13	16 24 170 1301 000	27	16 79 000 0020 000	27		
		16 24 170 1302 000	27				
16 11 170 5202 000	17						
16 11 170 5205 000	17						
16 11 170 5206 000	17	16 25 170 1301 000	29				
16 11 170 5207 000	17						



Please send me further information:

CD-ROM HARKIS® basic 
 DVD HARKIS® basic  



Interface Connectors



Device Connectivity



Industrial Connectors Han®

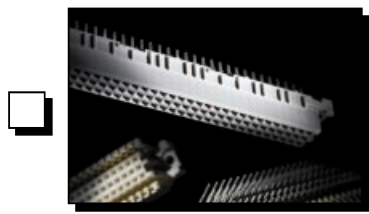

Connectors DIN 41612

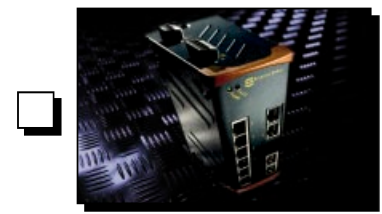

Ethernet Network Solutions Automation IT



Coaxial and Metric Connectors



Application brochure



TCA Connectors

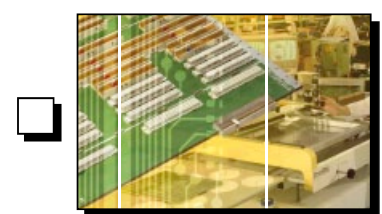

Backplanes and Integrated Systems

Sender: _____

Company: _____

Street: _____

Department: _____

Postcode/Town: _____

Name: _____

Country: _____

Prenome: _____

Phone: _____

Function: _____

Fax: _____

E-Mail: _____

Please send it by post or fax to your local HARTING representatives (see page addresses) or visit us under www.HARTING.com.

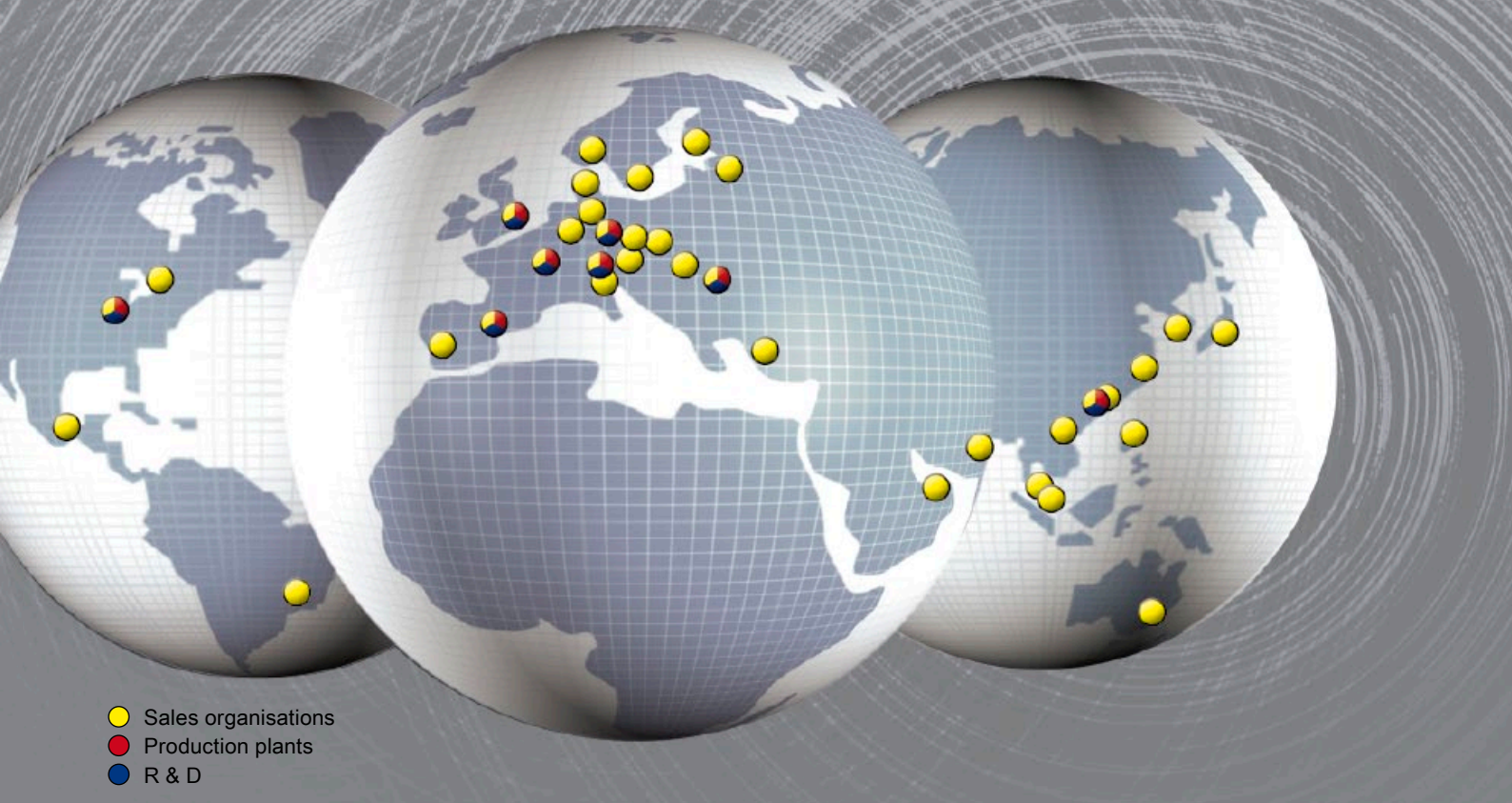

- Sales organisations
- Production plants
- R & D

Sales Network – worldwide



Albania

see Eastern Europe

Argentina

see Brazil

Armenia

see Eastern Europe

Australia

HARTING Pty Ltd
Suite 11 / 2 Enterprise Drive
Bundoora 3083, AUS-Victoria
Phone +61 3 9466 7088
Fax +61 3 9466 7099
au@HARTING.com
www.HARTING.com.au

Austria

HARTING Ges.m.b.H.
Deutschstraße 19, A-1230 Wien
Phone +431 6162121
Fax +431 6162121-21
at@HARTING.com
www.HARTING.at

Azerbaijan

see Eastern Europe

Bahrain

see Eastern Europe

Belgium

HARTING N.V./S.A.
Z.3 Doornveld 23, B-1731 Zellik
Phone +32 2 466 0190
Fax +32 2 466 7855
be@HARTING.com
www.HARTING.be

Bosnia and Herzegovina

see Eastern Europe

Brazil

HARTING Ltda.
Rua Major Paladino 128 –
Prédio 11
CEP 05307-000 – São Paulo –
SP – Brasil
Phone +55 11 5035 0073
Fax +55 11 5034 4743
br@HARTING.com
www.HARTING.com.br

Brunei

see Singapore

Bulgaria

see Eastern Europe

Canada

see USA

China

Zhuhai HARTING Limited
Shanghai branch
Room 5403, HK New World Tower
300 Huai Hai Road (M.), Luwan District
Shanghai 200021, China
Phone +86 21 6386 2200
Fax +86 21 6386 8636
cn@HARTING.com
www.HARTING.com.cn

Croatia

see Eastern Europe

Czech Republic

HARTING s.r.o.
Mlýnská 2, CZ-160 00 Praha 6
Phone +420 220 380 460
Fax +420 220 380 461
cz@HARTING.com
www.HARTING.cz

Denmark

HARTING ApS
Hjulgagervej 4a
DK - 7100 Vejle
Phone +45 70 25 00 32
Fax +45 75 80 64 99
dk@HARTING.com
www.HARTING.com

Eastern Europe

HARTING Eastern Europe GmbH
Bamberger Straße 7
D-01187 Dresden
Phone +49 351 4361 760
Fax +49 351 436 1770
Eastern.Europe@HARTING.com
www.HARTING.com

Estonia

see Eastern Europe

Finland

HARTING Oy
Teknobulevardi 3-5
FI-01530 Vantaa
Phone +358 207 291 510
Fax +358 207 291 511
fi@HARTING.com
www.HARTING.fi

France

HARTING France
181 avenue des Nations, Paris Nord 2
BP 66058 Tremblay en France
F-95972 Roissy Charles de Gaulle
Cédex
Phone +33 1 4938 3400
Fax +33 1 4863 2306
fr@HARTING.com
www.HARTING.fr

Germany

HARTING Deutschland GmbH & Co. KG
P.O. Box 2451, D-32381 Minden
Simeons carré 1, D-32427 Minden
Phone +49 571 8896 0
Fax +49 571 8896 282
de@HARTING.com
www.HARTING-Deutschland.de

Georgia

see Eastern Europe

Great Britain

HARTING Ltd., Caswell Road
Brackmills Industrial Estate
GB-Northampton, NN4 7PW
Phone +44 1604 827 500
Fax +44 1604 706 777
gb@HARTING.com
www.HARTING.co.uk

Hong Kong

HARTING (HK) Limited
Regional Office Asia Pacific
3512 Metroplaza Tower 1
223 Hing Fong Road
Kwai Fong, N. T., Hong Kong
Phone +852 2423 7338
Fax +852 2480 4378
ap@HARTING.com
www.HARTING.com.hk

Hungary

HARTING Magyarország Kft.
Fehérvári út 89-95, H-1119 Budapest
Phone +36 1 205 34 64
Fax +36 1 205 34 65
hu@HARTING.com
www.HARTING.hu

India

HARTING India Private Limited
No. D, 4th Floor, 'Doshi Towers'
No. 156 Poonamallee High Road
Kilpauk, Chennai 600 010
Tamil Nadu, India
Phone +91 44 435604 15 / 416
Fax +91 44 435604 17
in@HARTING.com
www.HARTING.co.in

Indonesia

see Malaysia

Israel

COMTEL
Israel Electronic Solutions Ltd.
Bet Hapamon, 20 Hataas st.
P.O.Box 66
Kefar-Saba 44425
Phone +972-9-7677240
Fax +972-9-7677243
sales@comtel.co.il
www.comtel.co.il

Italy

HARTING SpA
Via Dell' Industria 7
I-20090 Vimodrone (Milano)
Phone +39 02 250801
Fax +39 02 2650 597
it@HARTING.com
www.HARTING.it

Japan

HARTING K. K.
Yusen Shin-Yokohama 1 Chome Bldg., 2F
1-7-9, Shin-Yokohama, Kohoku
Yokohama 222-0033 Japan
Phone +81 45 476 3456
Fax +81 45 476 3466
jp@HARTING.com
www.HARTING.co.jp

Jordan

see United Arab Emirates

Kazakhstan

see Eastern Europe

Kirghizia

see Eastern Europe

Korea (South)

HARTING Korea Limited
#308 Yatap Leaders Building
342-1, Yatap-dong, Bundang-gu
Sungnam-City, Kyunggi-do
463-828, Republic of Korea
Phone +82 31 781 4615
Fax +82 31 781 4616
kr@HARTING.com
www.HARTING.co.kr

Kosovo

see Eastern Europe

Kuwait

see United Arab Emirates

Latvia

see Eastern Europe

Lithuania

see Eastern Europe

Macedonia

see Eastern Europe

Malaysia (Office)

HARTING Singapore Pte Ltd
Malaysia Branch
11-02 Menara Amcorp
Jln. Persiaran Barat
46200 PJ, Sel. D. E., Malaysia
Phone +60 3 / 7955 6173
Fax +60 3 / 7955 5126
sg@HARTING.com

Montenegro

see Eastern Europe

Netherlands

HARTING B.V.
Larenweg 44
NL-5234 KA 's-Hertogenbosch
Postbus 3526
NL-5203 DM 's-Hertogenbosch
Phone +31 736 410 404
Fax +31 736 440 699
nl@HARTING.com
www.HARTINGbv.nl

New Zealand

see Australia

Norway

HARTING A/S
Østensjøveien 36, N-0667 Oslo
Phone +47 22 700 555
Fax +47 22 700 570
no@HARTING.com
www.HARTING.no

Pakistan

see United Arab Emirates

Philippines

see Malaysia

Poland

HARTING Polska Sp. z o. o
ul. Kamieńskiego 201-219
PL-51-126 Wrocław
Phone +48 71 352 81 71
Fax +48 71 320 74 44
pl@HARTING.com
www.HARTING.pl

Portugal

HARTING Iberia, S. A.
Avda. Josep Tarradellas 20-30 4º 6a
E-08029 Barcelona
Phone +351 219 673 177
Fax +351 219 678 457
es@HARTING.com
www.HARTING.es/pt

Qatar

see United Arab Emirates

Republic of Moldova

see Eastern Europe

Romania

HARTING Romania SCS
Europa Unita str. 21
550018-Sibiu, Romania
Phone +40 369-102 671
Fax +40 369-102 622
ro@HARTING.com
www.HARTING.com

Russia

HARTING ZAO
Maliy Sampsoniyevsky prospect 2A
194044 Saint Petersburg, Russia
Phone +7 812 327 6477
Fax +7 812 327 6478
ru@HARTING.com
www.HARTING.ru

Saudi Arabia

see United Arab Emirates

Serbia

see Eastern Europe

Singapore

HARTING Singapore Pte Ltd.
25 International Business Park
#02-06 German Centre
Singapore 609916
Phone +65 6225 5285
Fax +65 6225 9947
sg@HARTING.com
www.HARTING.sg

Slovakia

HARTING s.r.o.
Sales office Slovakia
Povážska 2, SK - 940 67 Nové Zámky
Phone +421 356-493 993
Fax +421 356-402 114
sk@HARTING.com
www.HARTING.sk

Slovenia

see Eastern Europe

South Africa

Cabcon Technologies (PTY) Ltd
P.O. Box 13002, Northmead, 1511
Phone +27 1184533258
Fax +27 118454077
cabcon@mweb.co.za

Spain

HARTING Iberia S.A.
Avda. Josep Tarradellas 20-30 4º 6ª
E-08029 Barcelona
Phone +34 93 363 84 75
Fax +34 93 419 95 85
es@HARTING.com
www.HARTING.es

Sweden

HARTING AB
Gustavslundsvägen 141 B 4tr
S-167 51 Bromma
Phone +46 8 445 7171
Fax +46 8 445 7170
se@HARTING.com
www.HARTING.se

Switzerland

HARTING AG
Industriestrasse 26
CH-8604 Volketswil
Phone +41 44 908 20 60
Fax +41 44 908 20 69
ch@HARTING.com
www.HARTING.ch

Taiwan

HARTING R.O.C. Limited
Room 1, 5/F
495 GuangFu South Road
RC-110 Taipei, Taiwan
Phone +886 2 2758 6177
Fax +886 2 2758 7177
tw@HARTING.com
www.HARTING.com.tw

Tajikistan

see Eastern Europe

Thailand

see Malaysia

Turkey

HARTING TURKEI Elektronik Ltd. Şti.
Barbaros Mah. Dereboyu Cad.
Fesleğen Sok.
Uphill Towers, A-1b Kat:8 D:45
34746 Ataşehir, İstanbul
Phone +90 216 688 81 00
Fax +90 216 688 81 01
tr@HARTING.com
www.HARTING.com.tr

Turkmenistan

see Eastern Europe

United Arab Emirates

Eurotech Fzc
Office Bldg-36, Office No. G36-02
P.O. Box 49602
Hamriyah Free Zone, Sharjah
Phone +971 6 5262077
Fax +971 6 5262117
sales@eurotech.ae
www.eurotech.ae

Ukraine

see Eastern Europe

USA

HARTING Inc. of North America
1370 Bowes Road
USA-Elgin, Illinois 60123
Phone +1 (877) 741-1500 (toll free)
Fax +1 (866) 278-0307 (Inside Sales)
us@HARTING.com
www.HARTING-USA.com

Uzbekistan

see Eastern Europe

Vietnam (Office)

HARTING Singapore Pte Ltd
Hanoi Representative Office
Suite 518, 5th Floor
Press Club Building
59A Ly Thai To Street
Hoan Kiem District
Hanoi, Vietnam
Phone +84 4 / 3936 7851
Fax +84 4 / 3936 8069
sg@HARTING.com

Distributors – worldwide



Farnell:

www.farnell.com

RS Components:

www.rs-components.com

FUTURE Electronics:

www.futureelectronics.com

Other countries and general contact



HARTING Electronics GmbH & Co. KG
P.O. Box 1433
32328 Espelkamp - Germany
Phone +49 5772/47-97200
Fax +49 5772/47-777
electronics@HARTING.com



Pushing Performance

www.HARTING.com